

## Pseudo Wire Emulation Edge-to-Edge (PWE3) Architecture

### Status of This Memo

This memo provides information for the Internet community. It does not specify an Internet standard of any kind. Distribution of this memo is unlimited.

### Copyright Notice

Copyright (C) The Internet Society (2005).

### Abstract

This document describes an architecture for Pseudo Wire Emulation Edge-to-Edge (PWE3). It discusses the emulation of services such as Frame Relay, ATM, Ethernet, TDM, and SONET/SDH over packet switched networks (PSNs) using IP or MPLS. It presents the architectural framework for pseudo wires (PWs), defines terminology, and specifies the various protocol elements and their functions.

### Table of Contents

1.	Introduction. . . . .	2
1.1.	Pseudo Wire Definition. . . . .	2
1.2.	PW Service Functionality. . . . .	3
1.3.	Non-Goals of This Document. . . . .	4
1.4.	Terminology . . . . .	4
2.	PWE3 Applicability. . . . .	6
3.	Protocol Layering Model . . . . .	6
3.1.	Protocol Layers . . . . .	7
3.2.	Domain of PWE3. . . . .	8
3.3.	Payload Types . . . . .	8
4.	Architecture of Pseudo Wires. . . . .	11
4.1.	Network Reference Model . . . . .	12
4.2.	PWE3 Pre-processing . . . . .	12
4.3.	Maintenance Reference Model . . . . .	16
4.4.	Protocol Stack Reference Model. . . . .	17
4.5.	Pre-processing Extension to Protocol Stack Reference Model . . . . .	17
5.	PW Encapsulation. . . . .	18

5.1.	Payload Convergence Layer . . . . .	19
5.2.	Payload-independent PW Encapsulation Layers . . . . .	21
5.3.	Fragmentation . . . . .	24
5.4.	Instantiation of the Protocol Layers. . . . .	24
6.	PW Demultiplexer Layer and PSN Requirements . . . . .	27
6.1.	Multiplexing. . . . .	27
6.2.	Fragmentation . . . . .	28
6.3.	Length and Delivery . . . . .	28
6.4.	PW-PDU Validation . . . . .	28
6.5.	Congestion Considerations . . . . .	28
7.	Control Plane . . . . .	29
7.1.	Set-up or Teardown of Pseudo Wires. . . . .	29
7.2.	Status Monitoring . . . . .	30
7.3.	Notification of Pseudo Wire Status Changes. . . . .	30
7.4.	Keep-alive. . . . .	31
7.5.	Handling Control Messages of the Native Services. . . . .	32
8.	Management and Monitoring . . . . .	32
8.1.	Status and Statistics . . . . .	32
8.2.	PW SNMP MIB Architecture. . . . .	33
8.3.	Connection Verification and Traceroute. . . . .	36
9.	IANA Considerations . . . . .	37
10.	Security Considerations . . . . .	37
11.	Acknowledgements. . . . .	38
12.	References. . . . .	38
12.1.	Normative References . . . . .	38
12.2.	Informative References . . . . .	39
13.	Co-Authors. . . . .	40
14.	Editors' Addresses. . . . .	41
	Full Copyright Statement. . . . .	42

## 1. Introduction

This document describes an architecture for Pseudo Wire Emulation Edge-to-Edge (PWE3) in support of [RFC3916]. It discusses the emulation of services such as Frame Relay, ATM, Ethernet, TDM, and SONET/SDH over packet switched networks (PSNs) using IP or MPLS. It presents the architectural framework for pseudo wires (PWs), defines terminology, and specifies the various protocol elements and their functions.

### 1.1. Pseudo Wire Definition

PWE3 is a mechanism that emulates the essential attributes of a telecommunications service (such as a T1 leased line or Frame Relay) over a PSN. PWE3 is intended to provide only the minimum necessary functionality to emulate the wire with the required degree of faithfulness for the given service definition. Any required switching functionality is the responsibility of a forwarder function

(FWRD). Any translation or other operation needing knowledge of the payload semantics is carried out by native service processing (NSP) elements. The functional definition of any FWRD or NSP elements is outside the scope of PWE3.

The required functions of PWs include encapsulating service-specific bit streams, cells, or PDUs arriving at an ingress port and carrying them across an IP path or MPLS tunnel. In some cases it is necessary to perform other operations such as managing their timing and order, to emulate the behavior and characteristics of the service to the required degree of faithfulness.

From the perspective of Customer Edge Equipment (CE), the PW is characterized as an unshared link or circuit of the chosen service. In some cases, there may be deficiencies in the PW emulation that impact the traffic carried over a PW and therefore limit the applicability of this technology. These limitations must be fully described in the appropriate service-specific documentation.

For each service type, there will be one default mode of operation that all PEs offering that service type must support. However, optional modes may be defined to improve the faithfulness of the emulated service, if it can be clearly demonstrated that the additional complexity associated with the optional mode is offset by the value it offers to PW users.

## 1.2. PW Service Functionality

PWs provide the following functions in order to emulate the behavior and characteristics of the native service.

- o Encapsulation of service-specific PDUs or circuit data arriving at the PE-bound port (logical or physical).
- o Carriage of the encapsulated data across a PSN tunnel.
- o Establishment of the PW, including the exchange and/or distribution of the PW identifiers used by the PSN tunnel endpoints.
- o Managing the signaling, timing, order, or other aspects of the service at the boundaries of the PW.
- o Service-specific status and alarm management.

### 1.3. Non-Goals of This Document

The following are non-goals for this document:

- o The on-the-wire specification of PW encapsulations.
- o The detailed definition of the protocols involved in PW setup and maintenance.

The following are outside the scope of PWE3:

- o Any multicast service not native to the emulated medium. Thus, Ethernet transmission to a "multicast" IEEE-48 address is in scope, but multicast services such as MARS [RFC2022] that are implemented on top of the medium are not.
- o Methods to signal or control the underlying PSN.

### 1.4. Terminology

This document uses the following definitions of terms. These terms are illustrated in context in Figure 2.

Attachment Circuit (AC)	The physical or virtual circuit attaching a CE to a PE. An attachment Circuit may be, for example, a Frame Relay DLCI, an ATM VPI/VCI, an Ethernet port, a VLAN, a PPP connection on a physical interface, a PPP session from an L2TP tunnel, or an MPLS LSP. If both physical and virtual ACs are of the same technology (e.g., both ATM, both Ethernet, both Frame Relay), the PW is said to provide "homogeneous transport"; otherwise, it is said to provide "heterogeneous transport".
CE-bound	The traffic direction in which PW-PDUs are received on a PW via the PSN, processed, and then sent to the destination CE.
CE Signaling	Messages sent and received by the CE's control plane. It may be desirable or even necessary for the PE to participate in or to monitor this signaling in order to emulate the service effectively.
Control Word (CW)	A four-octet header used in some encapsulations to carry per-packet information when the PSN is MPLS.

Customer Edge (CE)	A device where one end of a service originates and/or terminates. The CE is not aware that it is using an emulated service rather than a native service.
Forwarder (FWRD)	A PE subsystem that selects the PW to use in order to transmit a payload received on an AC.
Fragmentation	The action of dividing a single PDU into multiple PDUs before transmission with the intent of the original PDU being reassembled elsewhere in the network. Packets may undergo fragmentation if they are larger than the MTU of the network they will traverse.
Maximum Transmission Unit (MTU)	The packet size (excluding data link header) that an interface can transmit without needing to fragment.
Native Service Processing (NSP)	Processing of the data received by the PE from the CE before presentation to the PW for transmission across the core, or processing of the data received from a PW by a PE before it is output on the AC. NSP functionality is defined by standards bodies other than the IETF, such as ITU-T, ANSI, or ATMF.)
Packet Switched Network (PSN)	Within the context of PWE3, this is a network using IP or MPLS as the mechanism for packet forwarding.
PE-Bound	The traffic direction in which information from a CE is adapted to a PW, and PW-PDUs are sent into the PSN.
PE/PW Maintenance	Used by the PEs to set up, maintain, and tear down the PW. It may be coupled with CE Signaling in order to manage the PW effectively.
Protocol Data Unit (PDU)	The unit of data output to, or received from, the network by a protocol layer.
Provider Edge (PE)	A device that provides PWE3 to a CE.
Pseudo Wire (PW)	A mechanism that carries the essential elements of an emulated service from one PE to one or more other PEs over a PSN.

Pseudo Wire Emulation Edge to Edge (PWE3)	A mechanism that emulates the essential attributes of service (such as a T1 leased line or Frame Relay) over a PSN.
Pseudo Wire PDU (PW-PDU)	A PDU sent on the PW that contains all of the data and control information necessary to emulate the desired service.
PSN Tunnel	A tunnel across a PSN, inside which one or more PWs can be carried.
PSN Tunnel Signaling	Used to set up, maintain, and tear down the underlying PSN tunnel.
PW Demultiplexer	Data-plane method of identifying a PW terminating at a PE.
Time Domain Multiplexing (TDM)	Time Division Multiplexing. Frequently used to refer to the synchronous bit streams at rates defined by G.702.
Tunnel	A method of transparently carrying information over a network.

## 2. PWE3 Applicability

The PSN carrying a PW will subject payload packets to loss, delay, delay variation, and re-ordering. During a network transient there may be a sustained period of impaired service. The applicability of PWE3 to a particular service depends on the sensitivity of that service (or the CE implementation) to these effects, and on the ability of the adaptation layer to mask them. Some services, such as IP over FR over PWE3, may prove quite resilient to IP and MPLS PSN characteristics. Other services, such as the interconnection of PBX systems via PWE3, will require more careful consideration of the PSN and adaptation layer characteristics. In some instances, traffic engineering of the underlying PSN will be required, and in some cases the constraints may make the required service guarantees impossible to provide.

## 3. Protocol Layering Model

The PWE3 protocol-layering model is intended to minimize the differences between PWs operating over different PSN types. The design of the protocol-layering model has the goals of making each PW definition independent of the underlying PSN, and of maximizing the reuse of IETF protocol definitions and their implementations.

### 3.1. Protocol Layers

The logical protocol-layering model required to support a PW is shown in Figure 1.

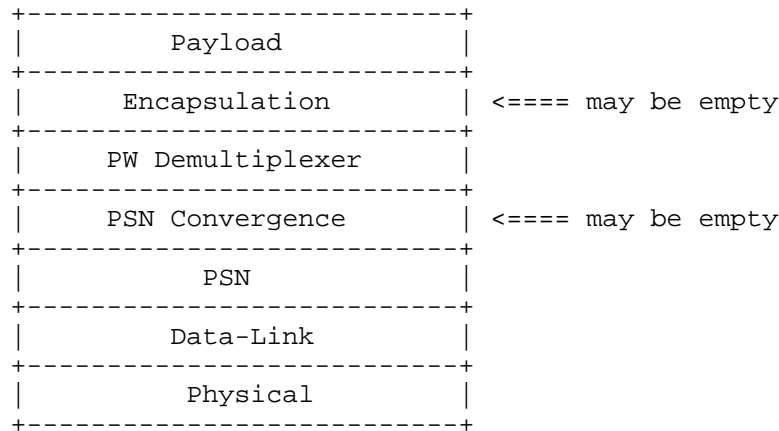

Figure 1. Logical Protocol Layering Model

The payload is transported over the Encapsulation Layer. The Encapsulation Layer carries any information, not already present within the payload itself, that is needed by the PW CE-bound PE interface to send the payload to the CE via the physical interface. If no further information is needed in the payload itself, this layer is empty.

The Encapsulation Layer also provides support for real-time processing, and if needed for sequencing.

The PW Demultiplexer layer provides the ability to deliver multiple PWs over a single PSN tunnel. The PW demultiplexer value used to identify the PW in the data plane may be unique per PE, but this is not a PWE3 requirement. It must, however, be unique per tunnel endpoint. If it is necessary to identify a particular tunnel, then that is the responsibility of the PSN layer.

The PSN Convergence layer provides the enhancements needed to make the PSN conform to the assumed PSN service requirement. Therefore, this layer provides a consistent interface to the PW, making the PW independent of the PSN type. If the PSN already meets the service requirements, this layer is empty.

The PSN header, MAC/Data-Link, and Physical Layer definitions are outside the scope of this document. The PSN can be IPv4, IPv6, or MPLS.

### 3.2. Domain of PWE3

PWE3 defines the Encapsulation Layer, the method of carrying various payload types, and the interface to the PW Demultiplexer Layer. It is expected that the other layers will be provided by tunneling methods such as L2TP or MPLS over the PSN.

### 3.3. Payload Types

The payload is classified into the following generic types of native data units:

- o Packet
- o Cell
- o Bit stream
- o Structured bit stream

Within these generic types there are specific service types:

Generic Payload Type	PW Service
-----	-----
Packet	Ethernet (all types), HDLC framing, Frame Relay, ATM AAL5 PDU.
Cell	ATM.
Bit stream	Unstructured E1, T1, E3, T3.
Structured bit stream	SONET/SDH (e.g., SPE, VT, NxDS0).

#### 3.3.1. Packet Payload

A packet payload is a variable-size data unit delivered to the PE via the AC. A packet payload may be large compared to the PSN MTU. The delineation of the packet boundaries is encapsulation specific. HDLC or Ethernet PDUs can be considered examples of packet payloads. Typically, a packet will be stripped of transmission overhead such as HDLC flags and stuffing bits before transmission over the PW.

A packet payload would normally be relayed across the PW as a single unit. However, there will be cases where the combined size of the packet payload and its associated PWE3 and PSN headers exceeds the PSN path MTU. In these cases, some fragmentation methodology has to be applied. This may, for example, be the case when a user provides



the service and attaches to the service provider via Ethernet, or when nested pseudo-wires are involved. Fragmentation is discussed in more detail in section 5.3.

A packet payload may need sequencing and real-time support.

In some situations, the packet payload may be selected from the packets presented on the emulated wire on the basis of some sub-multiplexing technique. For example, one or more Frame Relay PDUs may be selected for transport over a particular pseudo wire based on the Frame Relay Data-Link Connection Identifier (DLCI), or, in the case of Ethernet payloads, by using a suitable MAC bridge filter. This is a forwarder function, and this selection would therefore be made before the packet was presented to the PW Encapsulation Layer.

### 3.3.2. Cell Payload

A cell payload is created by capturing, transporting, and replaying groups of octets presented on the wire in a fixed-size format. The delineation of the group of bits that comprise the cell is specific to the encapsulation type. Two common examples of cell payloads are ATM 53-octet cells, and the larger 188-octet MPEG Transport Stream packets [DVB].

To reduce per-PSN packet overhead, multiple cells may be concatenated into a single payload. The Encapsulation Layer may consider the payload complete on the expiry of a timer, after a fixed number of cells have been received or when a significant cell (e.g., an ATM OAM cell) has been received. The benefit of concatenating multiple PDUs should be weighed against a possible increase in packet delay variation and the larger penalty incurred by packet loss. In some cases, it may be appropriate for the Encapsulation Layer to perform some type of compression, such as silence suppression or voice compression.

The generic cell payload service will normally need sequence number support and may also need real-time support. The generic cell payload service would not normally require fragmentation.

The Encapsulation Layer may apply some form of compression to some of these sub-types (e.g., idle cells may be suppressed).

In some instances, the cells to be incorporated in the payload may be selected by filtering them from the stream of cells presented on the wire. For example, an ATM PWE3 service may select cells based on their VCI or VPI fields. This is a forwarder function, and the selection would therefore be made before the packet was presented to the PW Encapsulation Layer.

### 3.3.3. Bit Stream

A bit stream payload is created by capturing, transporting, and replaying the bit pattern on the emulated wire, without taking advantage of any structure that, on inspection, may be visible within the relayed traffic (i.e., the internal structure has no effect on the fragmentation into packets).

In some instances it is possible to apply suppression to bit streams. For example, E1 and T1 send "all-ones" to indicate failure. This condition can be detected without any knowledge of the structure of the bit stream, and transmission of packetized can be data suppressed.

This service will require sequencing and real-time support.

### 3.3.4. Structured Bit Stream

A structured bit stream payload is created by using some knowledge of the underlying structure of the bit stream to capture, transport, and replay the bit pattern on the emulated wire.

Two important points distinguish structured and unstructured bit streams:

- o Some parts of the original bit stream may be stripped in the PSN-bound direction by an NSP block. For example, in Structured SONET the section and line overhead (and possibly more) may be stripped. A framer is required to enable such stripping. It is also required for frame/payload alignment for fractional T1/E1 applications.
- o The PW must preserve the structure across the PSN so that the CE-bound NSP block can insert it correctly into the reconstructed unstructured bit stream. The stripped information (such as SONET pointer justifications) may appear in the encapsulation layer to facilitate this reconstitution.

As an option, the Encapsulation Layer may also perform silence/idle suppression or similar compression on a structured bit stream.

Structured bit streams are distinguished from cells in that the structures may be too long to be carried in a single packet. Note that "short" structures are indistinguishable from cells and may benefit from the use of methods described in section 3.3.2.

This service requires sequencing and real-time support.

### 3.3.5. Principle of Minimum Intervention

To minimize the scope of information, and to improve the efficiency of data flow through the Encapsulation Layer, the payload should be transported as received, with as few modifications as possible [RFC1958].

This minimum intervention approach decouples payload development from PW development and requires fewer translations at the NSP in a system with similar CE interfaces at each end. It also prevents unwanted side effects due to subtle misrepresentation of the payload in the intermediate format.

An approach that does intervene can be more wire efficient in some cases and may result in fewer translations at the NSP whereby the CE interfaces are of different types. Any intermediate format effectively becomes a new framing type, requiring documentation and assured interoperability. This increases the amount of work for handling the protocol that the intermediate format carries and is undesirable.

## 4. Architecture of Pseudo Wires

This section describes the PWE3 architectural model.

4.1. Network Reference Model

Figure 2 illustrates the network reference model for point-to-point PWs.

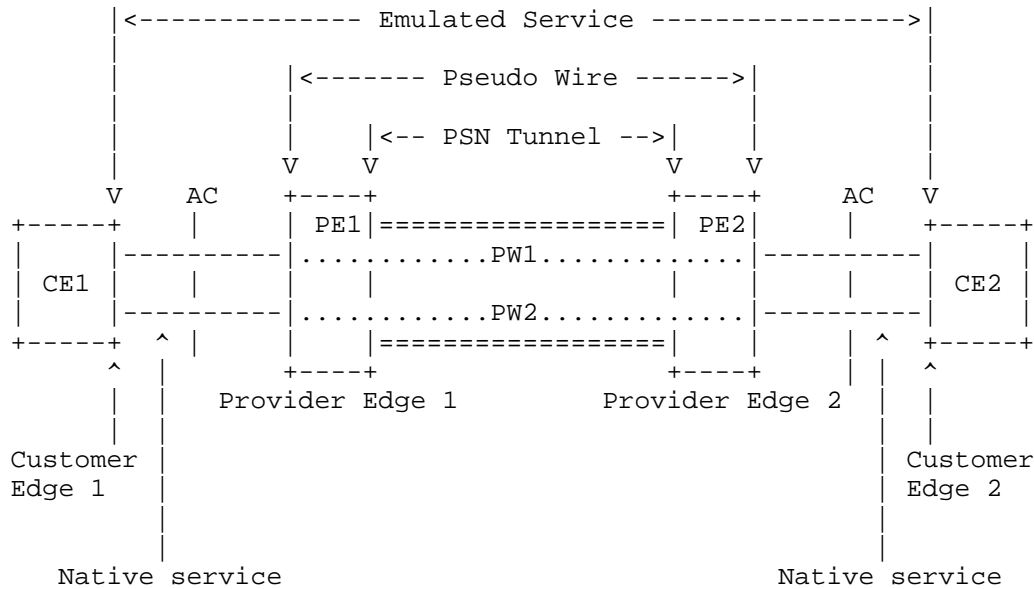

Figure 2. PWE3 Network Reference Model

The two PEs (PE1 and PE2) have to provide one or more PWs on behalf of their client CEs (CE1 and CE2) to enable the client CEs to communicate over the PSN. A PSN tunnel is established to provide a data path for the PW. The PW traffic is invisible to the core network, and the core network is transparent to the CEs. Native data units (bits, cells, or packets) arrive via the AC, are encapsulated in a PW-PDU, and are carried across the underlying network via the PSN tunnel. The PEs perform the necessary encapsulation and decapsulation of PW-PDUs and handle any other functions required by the PW service, such as sequencing or timing.

4.2. PWE3 Pre-processing

Some applications have to perform operations on the native data units received from the CE (including both payload and signaling traffic) before they are transmitted across the PW by the PE. Examples include Ethernet bridging, SONET cross-connect, translation of locally-significant identifiers such as VCI/VPI, or translation to another service type. These operations could be carried out in external equipment, and the processed data could be sent to the PE

over one or more physical interfaces. In most cases, could be in undertaking these operations within the PE provides cost and operational benefits. Processed data is then presented to the PW via a virtual interface within the PE. These pre-processing operations are included in the PWE3 reference model to provide a common reference point, but the detailed description of these operations is outside the scope of the PW definition given here.

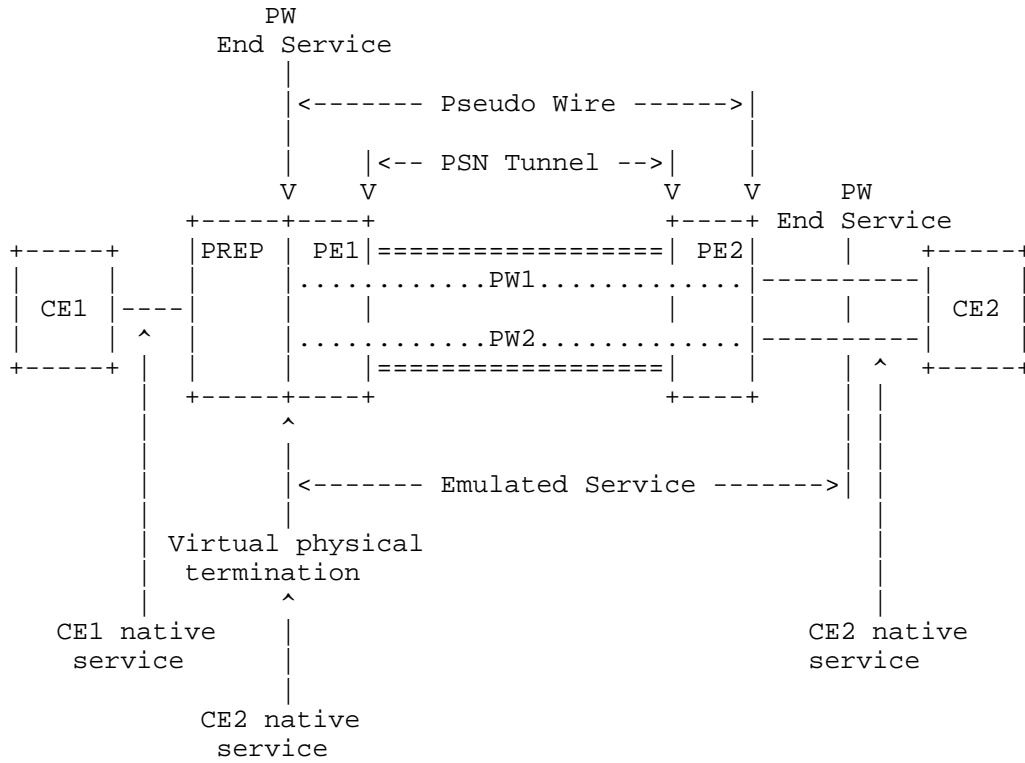

Figure 3. Pre-processing within the PWE3 Network Reference Model

Figure 3 shows the interworking of one PE with pre-processing (PREP), and a second without this functionality. This reference point emphasizes that the functional interface between PREP and the PW is that represented by a physical interface carrying the service. This effectively defines the necessary inter-working specification.

The operation of a system in which both PEs include PREP functionality is also supported.

The required pre-processing can be divided into two components:

- o Forwarder (FWRD)
- o Native Service Processing (NSP)

4.2.1. Forwarders

Some applications have to forward payload elements selectively from one or more ACs to one or more PWs. In such cases, there will also be a need to perform the inverse function on PWE3-PDUs received by a PE from the PSN. This is the function of the forwarder.

The forwarder selects the PW based on, for example, the incoming AC, the contents of the payload, or some statically and/or dynamically configured forwarding information.

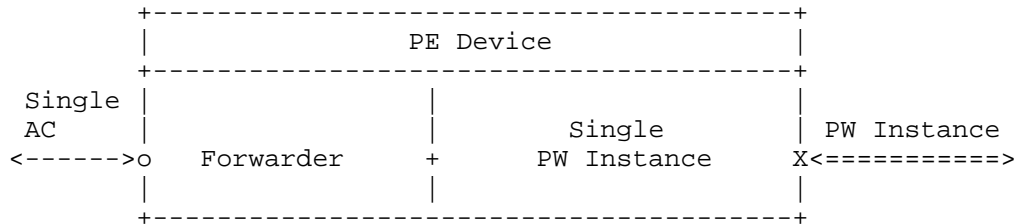

Figure 4a. Simple Point-to-Point Service

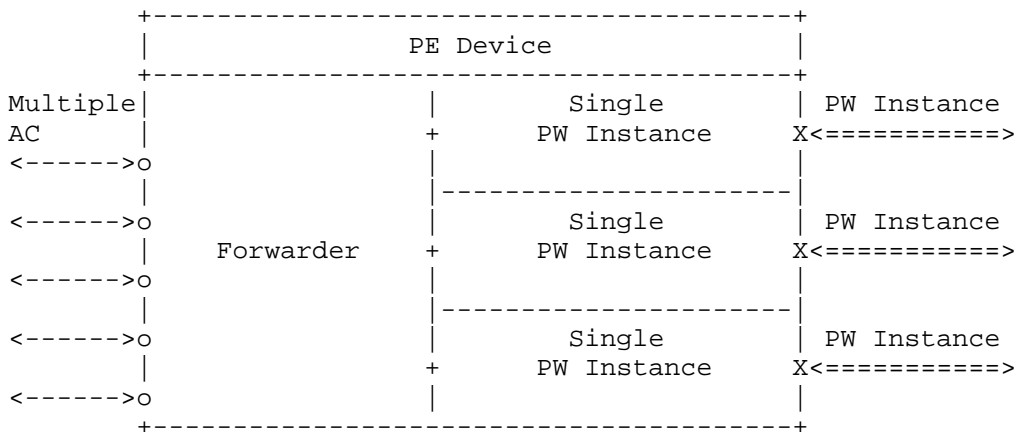

Figure 4b. Multiple AC to Multiple PW Forwarding

Figure 4a shows a simple forwarder that performs some type of filtering operation. Because the forwarder has a single input and a single output interface, filtering is the only type of forwarding

operation that applies. Figure 4b shows a more general forwarding situation where payloads are extracted from one or more ACs and directed to one or more PWs. In this case filtering, direction, and combination operations may be performed on the payloads. For example, if the AC were Frame Relay, the forwarder might perform Frame Relay switching and the PW instances might be the inter-switch links.

4.2.2. Native Service Processing

Some applications required some form of data or address translation, or some other operation requiring knowledge of the semantics of the payload. This is the function of the Native Service Processor (NSP).

The use of the NSP approach simplifies the design of the PW by restricting a PW to homogeneous operation. NSP is included in the reference model to provide a defined interface to this functionality. The specification of the various types of NSP is outside the scope of PWE3.

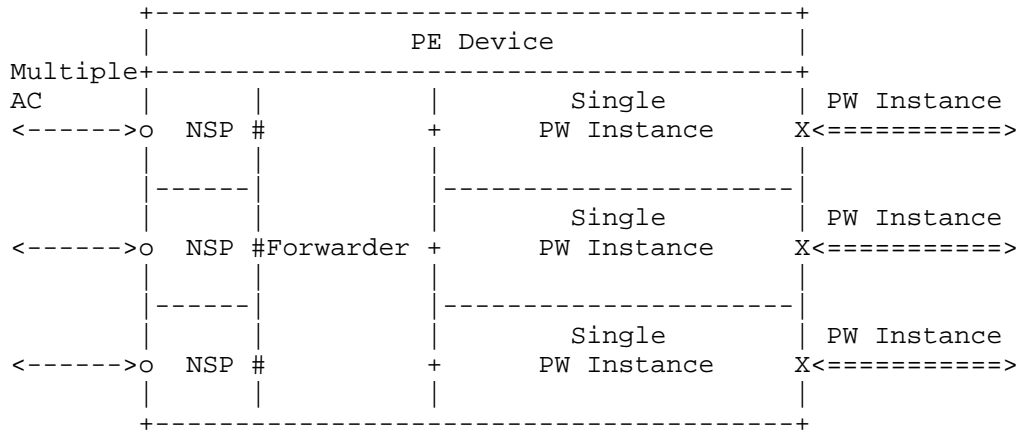

Figure 5. NSP in a Multiple AC to Multiple PW Forwarding PE

Figure 5 illustrates the relationship between NSP, forwarder, and PWs in a PE. The NSP function may apply any transformation operation (modification, injection, etc.) on the payloads as they pass between the physical interface to the CE and the virtual interface to the forwarder. These transformation operations will, of course, be limited to those that have been implemented in the data path, and that are enabled by the PE configuration. A PE device may contain more than one forwarder.

This model also supports the operation of a system in which the NSP functionality includes terminating the data-link, and the application of Network Layer processing to the payload.

4.3. Maintenance Reference Model

Figure 6 illustrates the maintenance reference model for PWS.

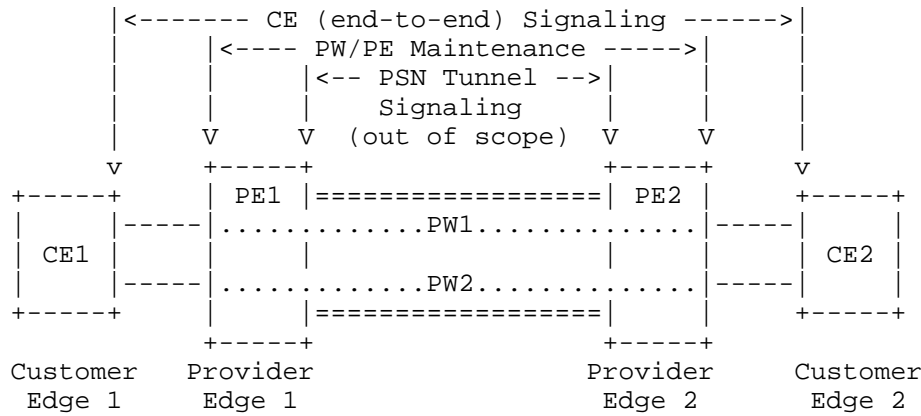

Figure 6. PWE3 Maintenance Reference Model

The following signaling mechanisms are required:

- o The CE (end-to-end) signaling is between the CEs. This signaling could be Frame Relay PVC status signaling, ATM SVC signaling, TDM CAS signaling, etc.
- o The PW/PE Maintenance is used between the PEs (or NSPs) to set up, maintain, and tear down PWS, including any required coordination of parameters.
- o The PSN Tunnel signaling controls the PW multiplexing and some elements of the underlying PSN. Examples are L2TP control protocol, MPLS LDP, and RSVP-TE. The definition of the information that PWE3 needs signaled is within the scope of PWE3, but the signaling protocol itself is not.



4.4. Protocol Stack Reference Model

Figure 7 illustrates the protocol stack reference model for PWs.

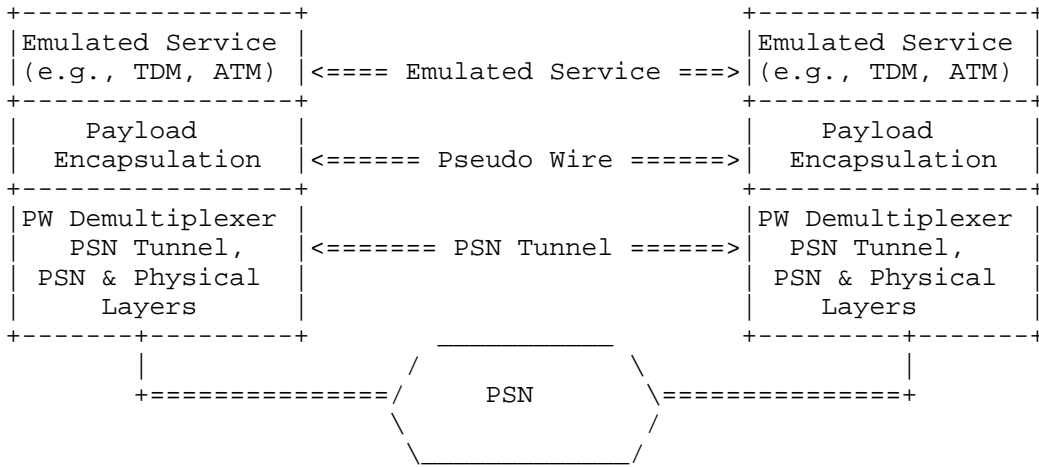

Figure 7. PWE3 Protocol Stack Reference Model

The PW provides the CE with an emulated physical or virtual connection to its peer at the far end. Native service PDUs from the CE are passed through an Encapsulation Layer at the sending PE and then sent over the PSN. The receiving PE removes the encapsulation and restores the payload to its native format for transmission to the destination CE.

4.5. Pre-processing Extension to Protocol Stack Reference Model

Figure 8 illustrates how the protocol stack reference model is extended to include the provision of pre-processing (forwarding and NSP). This shows the placement of the physical interface relative to the CE.

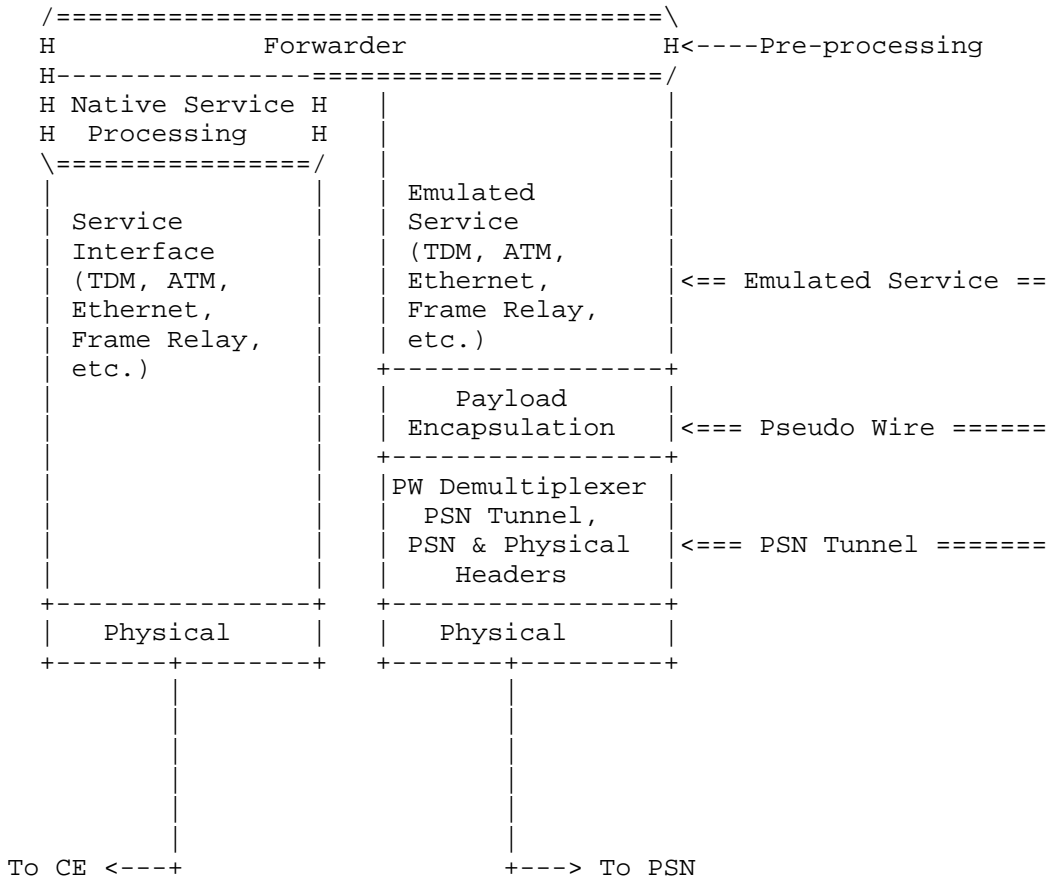

Figure 8. Protocol Stack Reference Model with Pre-processing

5. PW Encapsulation

The PW Encapsulation Layer provides the necessary infrastructure to adapt the specific payload type being transported over the PW to the PW Demultiplexer Layer used to carry the PW over the PSN.

The PW Encapsulation Layer consists of three sub-layers:

- o Payload Convergence
- o Timing
- o Sequencing

The PW Encapsulation sub-layering and its context with the protocol stack are shown in Figure 9.

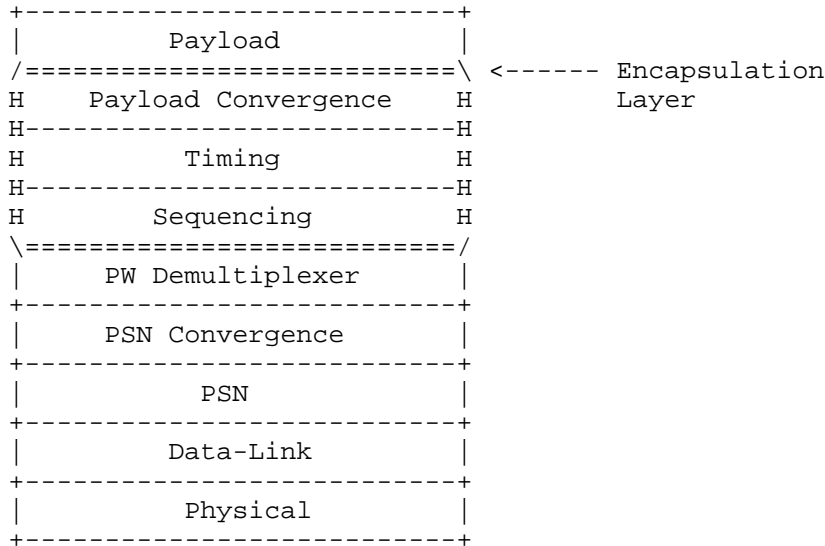

Figure 9. PWE3 Encapsulation Layer in Context

The Payload Convergence sub-layer is highly tailored to the specific payload type. However grouping a number of target payload types into a generic class, and then providing a single convergence sub-layer type common to the group, reduces the number of payload convergence sub-layer types. This decreases implementation complexity. The provision of per-packet signaling and other out-of-band information (other than sequencing or timing) is undertaken by this layer.

The Timing and Sequencing Layers provide generic services to the Payload Convergence Layer for all payload types that require them.

5.1. Payload Convergence Layer

5.1.1. Encapsulation

The primary task of the Payload Convergence Layer is the encapsulation of the payload in PW-PDUs. The native data units to be encapsulated may contain an L2 header or L1 overhead. This is service specific. The Payload Convergence header carries the additional information needed to replay the native data units at the CE-bound physical interface. The PW Demultiplexer header is not considered part of the PW header.

Not all the additional information needed to replay the native data units have to be carried in the PW header of the PW PDUs. Some information (e.g., service type of a PW) may be stored as state information at the destination PE during PW set up.

#### 5.1.2. PWE3 Channel Types

The PW Encapsulation Layer and its associated signaling require one or more of the following types of channels from its underlying PW Demultiplexer and PSN Layers (channel type 1 plus one or more of channel types 2 through 4):

1. A reliable control channel for signaling line events, status indications, and, in exceptional cases, CE-CE events that must be translated and sent reliably between PEs. PWE3 may need this type of control channel to provide faithful emulation of complex data-link protocols.
2. A high-priority, unreliable, sequenced channel. A typical use is for CE-to-CE signaling. "High priority" may simply be indicated via the DSCP bits for IP or the EXP bits for MPLS, giving the packet priority during transit. This channel type could also use a bit in the tunnel header itself to indicate that packets received at the PE should be processed with higher priority [RFC2474].
3. A sequenced channel for data traffic that is sensitive to packet reordering (one classification for use could be for any non-IP traffic).
4. An unsequenced channel for data traffic insensitive to packet order.

The data channels (2, 3, and 4 above) should be carried "in band" with one another to as much of a degree as is reasonably possible on a PSN.

Where end-to-end connectivity may be disrupted by address translation [RFC3022], access-control lists, firewalls, etc., the control channel may be able to pass traffic and setup the PW, while the PW data traffic is blocked by one or more of these mechanisms. In these cases unless the control channel is also carried "in band", the signaling to set up the PW will not confirm the existence of an end-to-end data path. In some cases there is a need to synchronize CE events with the data carried over a PW. This is especially the case

with TDM circuits (e.g., the on-hook/off-hook events in PSTN switches might be carried over a reliable control channel whereas the associated bit stream is carried over a sequenced data channel).

PWE3 channel types that are not needed by the supported PWs need not be included in such an implementation.

### 5.1.3. Quality of Service Considerations

Where possible, it is desirable to employ mechanisms to provide PW Quality of Service (QoS) support over PSNs.

## 5.2. Payload-Independent PW Encapsulation Layers

Two PWE3 Encapsulation sub-layers provide common services to all payload types: Sequencing and Timing. These services are optional and are only used if a particular PW instance needs them. If the service is not needed, the associated header may be omitted in order to conserve processing and network resources.

Sometimes a specific payload type will require transport with or without sequence and/or real-time support. For example, an invariant of Frame Relay transport is the preservation of packet order. Some Frame Relay applications expect delivery in order and may not cope with reordering of the frames. However, where the Frame Relay service is itself only being used to carry IP, it may be desirable to relax this constraint to reduce per-packet processing cost.

The guiding principle is that, when possible, an existing IETF protocol should be used to provide these services. When a suitable protocol is not available, the existing protocol should be extended or modified to meet the PWE3 requirements, thereby making that protocol available for other IETF uses. In the particular case of timing, more than one general method may be necessary to provide for the full scope of payload timing requirements.

### 5.2.1. Sequencing

The sequencing function provides three services: frame ordering, frame duplication detection, and frame loss detection. These services allow the emulation of the invariant properties of a physical wire. Support for sequencing depends on the payload type and may be omitted if it is not needed.

The size of the sequence-number space depends on the speed of the emulated service, and on the maximum time of the transient conditions in the PSN. A sequence number space greater than  $2^{16}$  may therefore be needed to prevent the sequence number space from wrapping during the transient.

#### 5.2.1.1. Frame Ordering

When packets carrying the PW-PDUs traverse a PSN, they may arrive out of order at the destination PE. For some services, the frames (control frames, data frames, or both) must be delivered in order. For these services, some mechanism must be provided for ensuring in-order delivery. Providing a sequence number in the sequence sub-layer header for each packet is one possible approach. Alternatively, it can be noted that sequencing is a subset of the problem of delivering timed packets, and that a single combined mechanism such as [RFC3550] may be employed.

There are two possible misordering strategies:

- o Drop misordered PW PDUs.
- o Try to sort PW PDUs into the correct order.

The choice of strategy will depend on

- o how critical the loss of packets is to the operation of the PW (e.g., the acceptable bit error rate),
- o the speeds of the PW and PSN,
- o the acceptable delay (as delay must be introduced to reorder), and
- o the expected incidence of misordering.

#### 5.2.1.2. Frame Duplication Detection

In rare cases, packets traversing a PW may be duplicated by the underlying PSN. For some services, frame duplication is not acceptable. For these services, some mechanism must be provided to ensure that duplicated frames will not be delivered to the destination CE. The mechanism may be the same as that used to ensure in-order frame delivery.

#### 5.2.1.3. Frame Loss Detection

A destination PE can determine whether a frame has been lost by tracking the sequence numbers of the PW PDUs received.

In some instances, if a PW PDU fails to arrive within a certain time, a destination PE will have to presume that it is lost. If a PW-PDU that has been processed as lost subsequently arrives, the destination PE must discard it.

#### 5.2.2. Timing

A number of native services have timing expectations based on the characteristics of the networks they were designed to travel over. The emulated service may have to duplicate these network characteristics as closely as possible: e.g., in delivering native traffic with bitrate, jitter, wander, and delay characteristics similar to those received at the sending PE.

In such cases, the receiving PE has to play out the native traffic as it was received at the sending PE. This relies on timing information either sent between the two PEs, or in some cases received from an external reference.

Therefore, Timing Sub-layer must support two timing functions: clock recovery and timed payload delivery. A particular payload type may require either or both of these services.

##### 5.2.2.1. Clock Recovery

Clock recovery is the extraction of output transmission bit timing information from the delivered packet stream, and it requires a suitable mechanism. A physical wire carries the timing information natively, but extracting timing from a highly jittered source, such as packet stream, is a relatively complex task. Therefore, it is desirable that an existing real-time protocol such as [RFC3550] be used for this purpose, unless it can be shown that this is unsuitable or unnecessary for a particular payload type.

##### 5.2.2.2. Timed Delivery

Timed delivery is the delivery of non-contiguous PW PDUs to the PW output interface with a constant phase relative to the input interface. The timing of the delivery may be relative to a clock derived from the packet stream received over the PSN clock recovery, or to an external clock.

### 5.3. Fragmentation

Ideally, a payload would be relayed across the PW as a single unit. However, there will be cases where the combined size of the payload and its associated PWE3 and PSN headers will exceed the PSN path MTU. When a packet size exceeds the MTU of a given network, fragmentation and reassembly have to be performed for the packet to be delivered. Since fragmentation and reassembly generally consume considerable network resources, as compared to simply switching a packet in its entirety, the need for fragmentation and reassembly throughout a network should be reduced or eliminated to the extent possible. Of particular concern for fragmentation and reassembly are aggregation points where large numbers of PWs are processed (e.g., at the PE).

Ideally, the equipment originating the traffic sent over the PW will have adaptive measures in place (e.g., [RFC1191], [RFC1981]) that ensure that packets needing to be fragmented are not sent. When this fails, the point closest to the sending host with fragmentation and reassembly capabilities should attempt to reduce the size of packets to satisfy the PSN MTU. Thus, in the reference model for PWE3 (Figure 3), fragmentation should first be performed at the CE if possible. Only if the CE cannot adhere to an acceptable MTU size for the PW should the PE attempt its own fragmentation method.

In cases where MTU management fails to limit the payload to a size suitable for transmission of the PW, the PE may fall back to either a generic PW fragmentation method or, if available, the fragmentation service of the underlying PSN.

It is acceptable for a PE implementation not to support fragmentation. A PE that does not will drop packets that exceed the PSN MTU, and the management plane of the encapsulating PE may be notified.

If the length of a L2/L1 frame, restored from a PW PDU, exceeds the MTU of the destination AC, it must be dropped. In this case, the management plane of the destination PE may be notified.

### 5.4. Instantiation of the Protocol Layers

This document does not address the detailed mapping of the Protocol Layering model to existing or future IETF standards. The instantiation of the logical Protocol Layering model is shown in Figure 9.



## 5.4.1.1. PWE3 over an IP PSN

The protocol definition of PWE3 over an IP PSN should employ existing IETF protocols where possible.

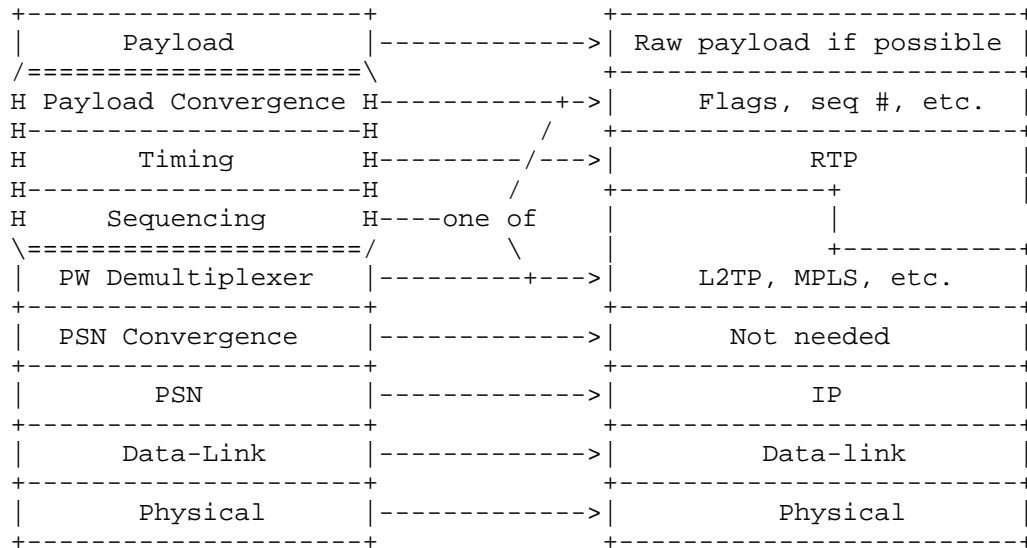

Figure 10. PWE3 over an IP PSN

Figure 10 shows the protocol layering for PWE3 over an IP PSN. As a rule, the payload should be carried as received from the NSP, with the Payload Convergence Layer provided when needed. However, in certain circumstances it may be justifiable to transmit the payload in some processed form. The reasons for this must be documented in the Encapsulation Layer definition for that payload type.

Where appropriate, explicit timing is provided by RTP [RFC3550], which, when used, also provides a sequencing service. When the PSN is UDP/IP, the RTP header follows the UDP header and precedes the PW control field. For all other cases the RTP header follows the PW control header.

The encapsulation layer may additionally carry a sequence number. Sequencing is to be provided either by RTP or by the PW encapsulation layer, but not by both.

PW Demultiplexing is provided by the PW label, which may take the form specified in a number of IETF protocols; e.g., an MPLS label [MPLSIP], an L2TP session ID [RFC3931], or a UDP port number [RFC768]. When PWs are carried over IP, the PSN Convergence Layer will not be needed.

As a special case, if the PW Demultiplexer is an MPLS label, the protocol architecture of section 5.4.2 can be used instead of the protocol architecture of this section.

5.4.2. PWE3 over an MPLS PSN

The MPLS ethos places importance on wire efficiency. By using a control word, some components of the PWE3 protocol layers can be compressed to increase this efficiency.

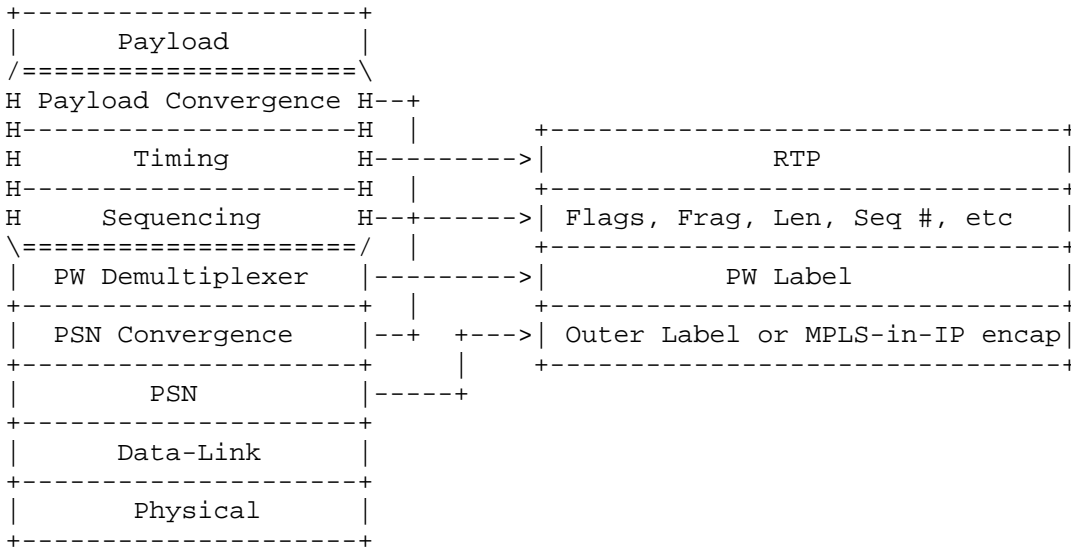

Figure 11. PWE3 over an MPLS PSN Using a Control Word

Figure 11 shows the protocol layering for PWE3 over an MPLS PSN. An inner MPLS label is used to provide the PW demultiplexing function. A control word is used to carry most of the information needed by the PWE3 Encapsulation Layer and the PSN Convergence Layer in a compact format. The flags in the control word provide the necessary payload convergence. A sequence field provides support for both in-order payload delivery and a PSN fragmentation service within the PSN Convergence Layer (supported by a fragmentation control method). Ethernet pads all frames to a minimum size of 64 bytes. The MPLS header does not include a length indicator. Therefore, to allow PWE3

to be carried in MPLS to pass correctly over an Ethernet data-link, a length correction field is needed in the control word. As with an IP PSN, where appropriate, timing is provided by RTP [RFC3550].

In some networks, it may be necessary to carry PWE3 over MPLS over IP. In these circumstances, the PW is encapsulated for carriage over MPLS as described in this section, and then a method of carrying MPLS over an IP PSN (such as GRE [RFC2784], [RFC2890]) is applied to the resultant PW-PDU.

#### 5.4.3. PW-IP Packet Discrimination

For MPLS PSNs, there is an additional constraint on the PW packet format. Some label switched routers detect IP packets based on the initial four bits of the packet content. To facilitate proper functioning, these bits in PW packets must not be the same as an IP version number in current use.

### 6. PW Demultiplexer Layer and PSN Requirements

PWE3 places three service requirements on the protocol layers used to carry it across the PSN:

- o Multiplexing
- o Fragmentation
- o Length and Delivery

#### 6.1. Multiplexing

The purpose of the PW Demultiplexer Layer is to allow multiple PWs to be carried in a single tunnel. This minimizes complexity and conserves resources.

Some types of native service are capable of grouping multiple circuits into a "trunk"; e.g., multiple ATM VCs in a VP, multiple Ethernet VLANs on a physical media, or multiple DS0 services within a T1 or E1. A PW may interconnect two end-trunks. That trunk would have a single multiplexing identifier.

When a MPLS label is used as a PW Demultiplexer, setting of the TTL value [RFC3032] in the PW label is application specific.

## 6.2. Fragmentation

If the PSN provides a fragmentation and reassembly service of adequate performance, it may be used to obtain an effective MTU that is large enough to transport the PW PDUs. See section 5.3 for a full discussion of the PW fragmentation issues.

## 6.3. Length and Delivery

PDU delivery to the egress PE is the function of the PSN Layer.

If the underlying PSN does not provide all the information necessary to determine the length of a PW-PDU, the Encapsulation Layer must provide it.

## 6.4. PW-PDU Validation

It is a common practice to use an error detection mechanism such as a CRC or similar mechanism to ensure end-to-end integrity of frames. The PW service-specific mechanisms must define whether the packet's checksum shall be preserved across the PW or be removed from PE-bound PDUs and then be recalculated for insertion in CE-bound data.

The former approach saves work, whereas the latter saves bandwidth. For a given implementation, the choice may be dictated by hardware restrictions, which may not allow the preservation of the checksum.

For protocols such as ATM and FR, the scope of the checksum is restricted to a single link. This is because the circuit identifiers (e.g., FR DLCI or ATM VPI/VCI) only have local significance and are changed on each hop or span. If the circuit identifier (and thus checksum) were going to change as part of the PW emulation, it would be more efficient to strip and recalculate the checksum.

The service-specific document for each protocol must describe the validation scheme to be used.

## 6.5. Congestion Considerations

The PSN carrying the PW may be subject to congestion. The congestion characteristics will vary with the PSN type, the network architecture and configuration, and the loading of the PSN.

If the traffic carried over the PW is known to be TCP friendly (by, for example, packet inspection), packet discard in the PSN will trigger the necessary reduction in offered load, and no additional congestion avoidance action is necessary.

If the PW is operating over a PSN that provides enhanced delivery, the PEs should monitor packet loss to ensure that the requested service is actually being delivered. If it is not, then the PE should assume that the PSN is providing a best-effort service and should use the best-effort service congestion avoidance measures described below.

If best-effort service is being used and the traffic is not known to be TCP friendly, the PEs should monitor packet loss to ensure that the loss rate is within acceptable parameters. Packet loss is considered acceptable if a TCP flow across the same network path and experiencing the same network conditions would achieve an average throughput, measured on a reasonable timescale, not less than that which the PW flow is achieving. This condition can be satisfied by implementing a rate-limiting measure in the NSP, or by shutting down one or more PWs. The choice of which approach to use depends upon the type of traffic being carried. Where congestion is avoided by shutting down a PW, a suitable mechanism must be provided to prevent it from immediately returning to service and causing a series of congestion pulses.

The comparison to TCP cannot be specified exactly but is intended as an "order-of-magnitude" comparison in timescale and throughput. The timescale on which TCP throughput is measured is the round-trip time of the connection. In essence, this requirement states that it is not acceptable to deploy an application (using PWE3 or any other transport protocol) on the best-effort Internet, which consumes bandwidth arbitrarily and does not compete fairly with TCP within an order of magnitude. One method of determining an acceptable PW bandwidth is described in [RFC3448].

## 7. Control Plane

This section describes PWE3 control plane services.

### 7.1. Setup or Teardown of Pseudo Wires

A PW must be set up before an emulated service can be established and must be torn down when an emulated service is no longer needed.

Setup or teardown of a PW can be triggered by an operator command, from the management plane of a PE, by signaling set-up or teardown of an AC (e.g., an ATM SVC), or by an auto-discovery mechanism.

During the setup process, the PEs have to exchange information (e.g., learn each other's capabilities). The tunnel signaling protocol may be extended to provide mechanisms that enable the PEs to exchange all necessary information on behalf of the PW.

Manual configuration of PWs can be considered a special kind of signaling and is allowed.

## 7.2. Status Monitoring

Some native services have mechanisms for status monitoring. For example, ATM supports OAM for this purpose. For these services, the corresponding emulated services must specify how to perform status monitoring.

## 7.3. Notification of Pseudo Wire Status Changes

### 7.3.1. Pseudo Wire Up/Down Notification

If a native service requires bi-directional connectivity, the corresponding emulated service can only be signaled as being up when the PW and PSN tunnels (if used), are functional in both directions.

Because the two CEs of an emulated service are not adjacent, a failure may occur at a place so that one or both physical links between the CEs and PEs remain up. For example, in Figure 2, if the physical link between CE1 and PE1 fails, the physical link between CE2 and PE2 will not be affected and will remain up. Unless CE2 is notified about the remote failure, it will continue to send traffic over the emulated service to CE1. Such traffic will be discarded at PE1. Some native services have failure notification so that when the services fail, both CEs will be notified. For these native services, the corresponding PWE3 service must provide a failure notification mechanism.

Similarly, if a native service has notification mechanisms so that all the affected services will change status from "Down" to "Up" when a network failure is fixed, the corresponding emulated service must provide a similar mechanism for doing so.

These mechanisms may already be built into the tunneling protocol. For example, the L2TP control protocol [RFC2661] [RFC3931] has this capability, and LDP has the ability to withdraw the corresponding MPLS label.

### 7.3.2. Misconnection and Payload Type Mismatch

With PWE3, misconnection and payload type mismatch can occur. Misconnection can breach the integrity of the system. Payload mismatch can disrupt the customer network. In both instances, there are security and operational concerns.

The services of the underlying tunneling mechanism and its associated control protocol can be used to mitigate this. As part of the PW setup, a PW-TYPE identifier is exchanged. This is then used by the forwarder and the NSP to verify the compatibility of the ACs.

#### 7.3.3. Packet Loss, Corruption, and Out-of-Order Delivery

A PW can incur packet loss, corruption, and out-of-order delivery on the PSN path between the PEs. This can affect the working condition of an emulated service. For some payload types, packet loss, corruption, and out-of-order delivery can be mapped either to a bit error burst, or to loss of carrier on the PW. If a native service has some mechanism to deal with bit error, the corresponding PWE3 service should provide a similar mechanism.

#### 7.3.4. Other Status Notification

A PWE3 approach may provide a mechanism for other status notifications, if any are needed.

#### 7.3.5. Collective Status Notification

The status of a group of emulated services may be affected identically by a single network incident. For example, when the physical link (or sub-network) between a CE and a PE fails, all the emulated services that go through that link (or sub-network) will fail. It is likely that a group of emulated services all terminate at a remote CE. There may also be multiple such CEs affected by the failure. Therefore, it is desirable that a single notification message be used to notify failure of the whole group of emulated services.

A PWE3 approach may provide a mechanism for notifying status changes of a group of emulated circuits. One possible method is to associate each emulated service with a group ID when the PW for that emulated service is set up. Multiple emulated services can then be grouped by associating them with the same group ID. In status notification, this group ID can be used to refer all the emulated services in that group. The group ID mechanism should be a mechanism provided by the underlying tunnel signaling protocol.

#### 7.4. Keep-Alive

If a native service has a keep-alive mechanism, the corresponding emulated service must provide a mechanism to propagate it across the PW. Transparently transporting keep-alive messages over the PW would follow the principle of minimum intervention. However, to reproduce

the semantics of the native mechanism accurately, some PWs may require an alternative approach, such as piggy-backing on the PW signaling mechanism.

#### 7.5. Handling Control Messages of the Native Services

Some native services use control messages for circuit maintenance. These control messages may be in-band (e.g., Ethernet flow control, ATM performance management, or TDM tone signaling) or out-of-band, (e.g., the signaling VC of an ATM VP, or TDM CCS signaling).

Given the principle of minimum intervention, it is desirable that the PEs participate as little as possible in the signaling and maintenance of the native services. This principle should not, however, override the need to emulate the native service satisfactorily.

If control messages are passed through, it may be desirable to send them by using either a higher priority or a reliable channel provided by the PW Demultiplexer layer. See Section 5.1.2, PWE3 Channel Types.

### 8. Management and Monitoring

This section describes the management and monitoring architecture for PWE3.

#### 8.1. Status and Statistics

The PE should report the status of the interface and tabulate statistics that help monitor the state of the network and help measure service-level agreements (SLAs). Typical counters include the following:

- o Counts of PW-PDUs sent and received, with and without errors.
- o Counts of sequenced PW-PDUs lost.
- o Counts of service PDUs sent and received over the PSN, with and without errors (non-TDM).
- o Service-specific interface counts.
- o One-way delay and delay variation.

These counters would be contained in a PW-specific MIB, and they should not replicate existing MIB counters.



## 8.2. PW SNMP MIB Architecture

This section describes the general architecture for SNMP MIBs used to manage PW services and the underlying PSN. The intent here is to provide a clear picture of how all the pertinent MIBs fit together to form a cohesive management framework for deploying PWE3 services. Note that the names of MIB modules used below are suggestions and do not necessarily require that the actual modules used to realize the components in the architecture be named exactly so.

### 8.2.1. MIB Layering

The SNMP MIBs created for PWE3 should fit the architecture shown in Figure 12. The architecture provides a layered modular model into which any supported emulated service can be connected to any supported PSN type. This model fosters reuse of as much functionality as possible. For instance, the emulated service layer MIB modules do not redefine the existing emulated service MIB module; rather, they only associate it with the pseudo wires used to carry the emulated service over the configured PSN. In this way, the PWE3 MIB architecture follows the overall PWE3 architecture.

The architecture does allow for the joining of unsupported emulated service or PSN types by simply defining additional MIB modules to associate new types with existing ones. These new modules can subsequently be standardized. Note that there is a separate MIB module for each emulated service, as well as one for each underlying PSN. These MIB modules may be used in various combinations as needed.



Figure 13 shows an example for a SONET PW carried over MPLS Traffic Engineering Tunnel and an LDP-signaled LSP.

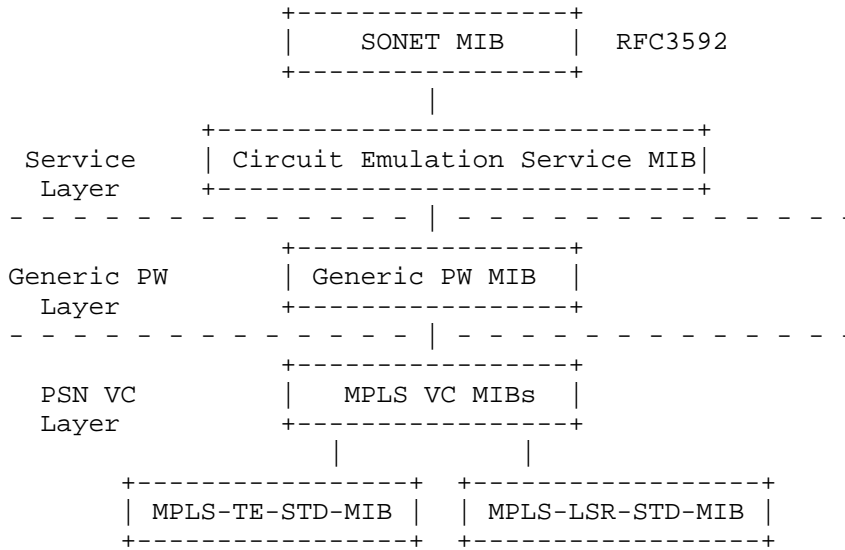

Figure 13. SONET PW over MPLS PSN Service-Specific Example

8.2.2. Service Layer MIB Modules

This conceptual layer in the model contains MIB modules used to represent the relationship between emulated PWE3 services such as Ethernet, ATM, or Frame Relay and the pseudo-wire used to carry that service across the PSN. This layer contains corresponding MIB modules used to mate or adapt those emulated services to the generic pseudo-wire representation these are represented in the "Generic PW MIB" functional block in Figure 13 above. This working group should not produce any MIB modules for managing the general service; rather, it should produce just those modules used to interface or adapt the emulated service onto the PWE3 management framework as shown above. For example, the standard SONET-MIB [RFC3592] is designed and maintained by another working group. The SONET-MIB is designed to manage the native service without PW emulation. However, the PWE3 working group is chartered to produce standards that show how to emulate existing technologies such as SONET/SDH over pseudo-wires rather than reinvent those modules.

### 8.2.3. Generic PW MIB Modules

The middle layer in the architecture is referred to as the Generic PW Layer. MIBs in this layer are responsible for providing pseudo-wire specific counters and service models used for monitoring and configuration of PWE3 services over any supported PSN service. That is, this layer provides a general model of PWE3 abstraction for management purposes. This MIB is used to interconnect the MIB modules residing in the Service Layer to the PSN VC Layer MIBs (see section 8.2.4).

### 8.2.4. PSN VC Layer MIB Modules

The third layer in the PWE3 management architecture is referred to as the PSN VC Layer. It is composed of MIBs that are specifically designed to associate pseudo-wires onto those underlying PSN transport technologies that carry the pseudo-wire payloads across the PSN. In general, this means that the MIB module provides a mapping between the emulated service that is mapped to the pseudo-wire via the Service Layer and the Generic PW MIB Layer onto the native PSN service. For example, in the case of MPLS, for example, it is required that the general VC service be mapped into MPLS LSPs via the MPLS-LSR-STD-MIB [RFC3813] or Traffic-Engineered (TE) Tunnels via the MPLS-TE-STD-MIB [RFC3812]. In addition, the MPLS-LDP-STD-MIB [RFC3815] may be used to reveal the MPLS labels that are distributed over the MPLS PSN in order to maintain the PW service. As with the native service MIB modules described earlier, the MIB modules used to manage the native PSN services are produced by other working groups that design and specify the native PSN services. These MIBs should contain the appropriate mechanisms for monitoring and configuring the PSN service that the emulated PWE3 service will function correctly.

### 8.3. Connection Verification and Traceroute

A connection verification mechanism should be supported by PWs. Connection verification and other alarm mechanisms can alert the operator that a PW has lost its remote connection. The opaque nature of a PW means that it is not possible to specify a generic connection verification or traceroute mechanism that passes this status to the CEs over the PW. If connection verification status of the PW is needed by the CE, it must be mapped to the native connection status method.

For troubleshooting purposes, it is sometimes desirable to know the exact functional path of a PW between PEs. This is provided by the traceroute service of the underlying PSN. The opaque nature of the PW means that this traceroute information is only available within the provider network; e.g., at the PEs.

## 9. IANA Considerations

IANA considerations will be identified in the PWE3 documents that define the PWE3 encapsulation, control, and management protocols.

## 10. Security Considerations

PWE3 provides no means of protecting the integrity, confidentiality, or delivery of the native data units. The use of PWE3 can therefore expose a particular environment to additional security threats. Assumptions that might be appropriate when all communicating systems are interconnected via a point-to-point or circuit-switched network may no longer hold when they are interconnected with an emulated wire carried over some types of PSN. It is outside the scope of this specification to fully analyze and review the risks of PWE3, particularly as these risks will depend on the PSN. An example should make the concern clear. A number of IETF standards employ relatively weak security mechanisms when communicating nodes are expected to be connected to the same local area network. The Virtual Router Redundancy Protocol [RFC3768] is one instance. The relatively weak security mechanisms represent a greater vulnerability in an emulated Ethernet connected via a PW.

Exploitation of vulnerabilities from within the PSN may be directed to the PW Tunnel end point so that PW Demultiplexer and PSN tunnel services are disrupted. Controlling PSN access to the PW Tunnel end point is one way to protect against this. By restricting PW Tunnel end point access to legitimate remote PE sources of traffic, the PE may reject traffic that would interfere with the PW Demultiplexing and PSN tunnel services.

Protection mechanisms must also address the spoofing of tunneled PW data. The validation of traffic addressed to the PW Demultiplexer end-point is paramount in ensuring integrity of PW encapsulation. Security protocols such as IPsec [RFC2401] may be used by the PW Demultiplexer Layer in order provide authentication and data integrity of the data between the PW Demultiplexer End-points.

IPsec may provide authentication, integrity, and confidentiality, of data transferred between two PEs. It cannot provide the equivalent services to the native service.

Based on the type of data being transferred, the PW may indicate to the PW Demultiplexer Layer that enhanced security services are required. The PW Demultiplexer Layer may define multiple protection profiles based on the requirements of the PW emulated service. CE-to-CE signaling and control events emulated by the PW and some data types may require additional protection mechanisms. Alternatively,

the PW Demultiplexer Layer may use peer authentication for every PSN packet to prevent spoofed native data units from being sent to the destination CE.

The unlimited transformation capability of the NSP may be perceived as a security risk. In practice the type of operation that the NSP may perform will be limited to those that have been implemented in the data path. A PE designed and managed to best current practice will have controls in place that protect and validate its configuration, and these will be sufficient to ensure that the NSP behaves as expected.

## 11. Acknowledgements

We thank Sasha Vainshtein for his work on Native Service Processing and advice on bit stream over PW services and Thomas K. Johnson for his work on the background and motivation for PWs.

We also thank Ron Bonica, Stephen Casner, Durai Chinnaiiah, Jayakumar Jayakumar, Ghassem Koleyni, Danny McPherson, Eric Rosen, John Rutemiller, Scott Wainner, and David Zelig for their comments and contributions.

## 12. References

### 12.1. Normative References

- [RFC3931] Lau, J., Townsley, M., and I. Goyret, "Layer Two Tunneling Protocol - Version 3 (L2TPv3)", RFC 3931, March 2005.
- [RFC768] Postel, J., "User Datagram Protocol", STD 6, RFC 768, August 1980.
- [RFC2401] Kent, S. and R. Atkinson, "Security Architecture for the Internet Protocol", RFC 2401, November 1998.
- [RFC2474] Nichols, K., Blake, S., Baker, F., and D. Black, "Definition of the Differentiated Services Field (DS Field) in the IPv4 and IPv6 Headers", RFC 2474, December 1998.
- [RFC3592] Tesink, K., "Definitions of Managed Objects for the Synchronous Optical Network/Synchronous Digital Hierarchy (SONET/SDH) Interface Type", RFC 3592, September 2003.

- [RFC2661] Townsley, W., Valencia, A., Rubens, A., Pall, G., Zorn, G., and B. Palter, "Layer Two Tunneling Protocol "L2TP"", RFC 2661, August 1999.
- [RFC2784] Farinacci, D., Li, T., Hanks, S., Meyer, D., and P. Traina, "Generic Routing Encapsulation (GRE)", RFC 2784, March 2000.
- [RFC2890] Dommety, G., "Key and Sequence Number Extensions to GRE", RFC 2890, September 2000.
- [RFC3032] Rosen, E., Tappan, D., Fedorkow, G., Rekhter, Y., Farinacci, D., Li, T., and A. Conta, "MPLS Label Stack Encoding", RFC 3032, January 2001.
- [RFC3550] Schulzrinne, H., Casner, S., Frederick, R., and V. Jacobson, "RTP: A Transport Protocol for Real-Time Applications", STD 64, RFC 3550, July 2003.

## 12.2. Informative References

- [DVB] EN 300 744 Digital Video Broadcasting (DVB); Framing structure, channel coding and modulation for digital terrestrial television (DVB-T), European Telecommunications Standards Institute (ETSI).
- [RFC3815] Cucchiara, J., Sjostrand, H., and J. Luciani, "Definitions of Managed Objects for the Multiprotocol Label Switching (MPLS), Label Distribution Protocol (LDP)", RFC 3815, June 2004.
- [RFC3813] Srinivasan, C., Viswanathan, A., and T. Nadeau, "Multiprotocol Label Switching (MPLS) Label Switching Router (LSR) Management Information Base (MIB)", RFC 3813, June 2004.
- [MPLSIP] Rosen et al, "Encapsulating MPLS in IP or Generic Routing Encapsulation (GRE)", Work in Progress, March 2004.
- [RFC1191] Mogul, J. and S. Deering, "Path MTU discovery", RFC 1191, November 1990.
- [RFC1958] Carpenter, B., "Architectural Principles of the Internet", RFC 1958, June 1996.
- [RFC1981] McCann, J., Deering, S., and J. Mogul, "Path MTU Discovery for IP version 6", RFC 1981, August 1996.

- [RFC2022] Armitage, G., "Support for Multicast over UNI 3.0/3.1 based ATM Networks", RFC 2022, November 1996.
- [RFC3768] Hinden, R., "Virtual Router Redundancy Protocol (VRRP)", RFC 3768, April 2004.
- [RFC3022] Srisuresh, P. and K. Egevang, "Traditional IP Network Address Translator (Traditional NAT)", RFC 3022, January 2001.
- [RFC3448] Handley, M., Floyd, S., Padhye, J., and J. Widmer, "TCP Friendly Rate Control (TFRC): Protocol Specification", RFC 3448, January 2003.
- [RFC3812] Srinivasan, C., Viswanathan, A., and T. Nadeau, "Multiprotocol Label Switching (MPLS) Traffic Engineering (TE) Management Information Base (MIB)", RFC 3812, June 2004.
- [RFC3916] Xiao, X., McPherson, D., and P. Pate, Eds, "Requirements for Pseudo-Wire Emulation Edge-to-Edge (PWE3)", RFC 3916, September 2004.

### 13. Co-Authors

The following are co-authors of this document:

Thomas K. Johnson  
Litchfield Communications

Kireeti Kompella  
Juniper Networks, Inc.

Andrew G. Malis  
Tellabs

Thomas D. Nadeau  
Cisco Systems

Tricci So  
Caspian Networks

W. Mark Townsley  
Cisco Systems



Craig White  
Level 3 Communications, LLC.

Lloyd Wood  
Cisco Systems

#### 14. Editors' Addresses

Stewart Bryant  
Cisco Systems  
250, Longwater  
Green Park  
Reading, RG2 6GB,  
United Kingdom

EEmail: [stbryant@cisco.com](mailto:stbryant@cisco.com)

Prayson Pate  
Overture Networks, Inc.  
507 Airport Boulevard  
Morrisville, NC, USA 27560

EEmail: [prayson.pate@overturenetworks.com](mailto:prayson.pate@overturenetworks.com)

## Full Copyright Statement

Copyright (C) The Internet Society (2005).

This document is subject to the rights, licenses and restrictions contained in BCP 78, and except as set forth therein, the authors retain all their rights.

This document and the information contained herein are provided on an "AS IS" basis and THE CONTRIBUTOR, THE ORGANIZATION HE/SHE REPRESENTS OR IS SPONSORED BY (IF ANY), THE INTERNET SOCIETY AND THE INTERNET ENGINEERING TASK FORCE DISCLAIM ALL WARRANTIES, EXPRESS OR IMPLIED, INCLUDING BUT NOT LIMITED TO ANY WARRANTY THAT THE USE OF THE INFORMATION HEREIN WILL NOT INFRINGE ANY RIGHTS OR ANY IMPLIED WARRANTIES OF MERCHANTABILITY OR FITNESS FOR A PARTICULAR PURPOSE.

## Intellectual Property

The IETF takes no position regarding the validity or scope of any Intellectual Property Rights or other rights that might be claimed to pertain to the implementation or use of the technology described in this document or the extent to which any license under such rights might or might not be available; nor does it represent that it has made any independent effort to identify any such rights. Information on the procedures with respect to rights in RFC documents can be found in BCP 78 and BCP 79.

Copies of IPR disclosures made to the IETF Secretariat and any assurances of licenses to be made available, or the result of an attempt made to obtain a general license or permission for the use of such proprietary rights by implementers or users of this specification can be obtained from the IETF on-line IPR repository at <http://www.ietf.org/ipr>.

The IETF invites any interested party to bring to its attention any copyrights, patents or patent applications, or other proprietary rights that may cover technology that may be required to implement this standard. Please address the information to the IETF at [ietf-ipr@ietf.org](mailto:ietf-ipr@ietf.org).

## Acknowledgement

Funding for the RFC Editor function is currently provided by the Internet Society.

