

Internet Engineering Task Force (IETF)
Request for Comments: 6527
Obsoletes: 2787
Category: Standards Track
ISSN: 2070-1721

K. Tata
Nokia
March 2012

Definitions of Managed Objects for
the Virtual Router Redundancy Protocol Version 3 (VRRPv3)

Abstract

This specification defines a portion of the Management Information Base (MIB) for use with network management based on the Simple Network Management Protocol (SNMP). In particular, it defines objects for configuring, monitoring, and controlling routers that employ the Virtual Router Redundancy Protocol Version 3 (VRRPv3) for both IPv4 and IPv6 as defined in RFC 5798. This memo obsoletes RFC 2787.

Status of This Memo

This is an Internet Standards Track document.

This document is a product of the Internet Engineering Task Force (IETF). It represents the consensus of the IETF community. It has received public review and has been approved for publication by the Internet Engineering Steering Group (IESG). Further information on Internet Standards is available in Section 2 of RFC 5741.

Information about the current status of this document, any errata, and how to provide feedback on it may be obtained at <http://www.rfc-editor.org/info/rfc6527>.

Copyright Notice

Copyright (c) 2012 IETF Trust and the persons identified as the document authors. All rights reserved.

This document is subject to BCP 78 and the IETF Trust's Legal Provisions Relating to IETF Documents (<http://trustee.ietf.org/license-info>) in effect on the date of publication of this document. Please review these documents carefully, as they describe your rights and restrictions with respect to this document. Code Components extracted from this document must include Simplified BSD License text as described in Section 4.e of the Trust Legal Provisions and are provided without warranty as described in the Simplified BSD License.

This document may contain material from IETF Documents or IETF Contributions published or made publicly available before November 10, 2008. The person(s) controlling the copyright in some of this material may not have granted the IETF Trust the right to allow modifications of such material outside the IETF Standards Process. Without obtaining an adequate license from the person(s) controlling the copyright in such materials, this document may not be modified outside the IETF Standards Process, and derivative works of it may not be created outside the IETF Standards Process, except to format it for publication as an RFC or to translate it into languages other than English.

Table of Contents

1. The Internet-Standard Management Framework	2
2. Introduction	3
3. Terminology	3
4. Relationship to RFC 2787	3
5. Relation to Interface Group (IF-MIB)	3
6. Multi-Stack Implementations	3
7. Interpretation of RFC 5798	3
8. VRRP MIB Structure and Design	4
9. VRRP Multi-Stack Scenario	4
10. Definitions	7
11. Security Considerations	27
12. IANA Considerations	29
13. Normative References	29
14. Informative References	30
15. Acknowledgments	31

1. The Internet-Standard Management Framework

For a detailed overview of the documents that describe the current Internet-Standard Management Framework, please refer to section 7 of RFC 3410 [RFC3410].

Managed objects are accessed via a virtual information store, termed the Management Information Base or MIB. MIB objects are generally accessed through the Simple Network Management Protocol (SNMP). Objects in the MIB are defined using the mechanisms defined in the Structure of Management Information (SMI). This memo specifies a MIB module that is compliant to the SMIV2, which is described in STD 58, RFC 2578 [RFC2578], STD 58, RFC 2579 [RFC2579] and STD 58, RFC 2580 [RFC2580].

2. Introduction

This specification defines a portion of the MIB for use with SNMP-based network management. In particular, it defines objects for configuring, monitoring, and controlling routers that employ the Virtual Router Redundancy Protocol Version 3 (VRRPv3) for both IPv4 and IPv6 as defined in RFC 5798 [RFC5798].

3. Terminology

The key words "MUST", "MUST NOT", "REQUIRED", "SHALL", "SHALL NOT", "SHOULD", "SHOULD NOT", "RECOMMENDED", "NOT RECOMMENDED", "MAY", and "OPTIONAL" in this document are to be interpreted as described in RFC 2119 [RFC2119].

4. Relationship to RFC 2787

This document obsoletes RFC 2787 [RFC2787]. The major changes in this document reflect changes in the VRRP protocol between RFC 2338 [RFC2338] and RFC 5798 [RFC5798]. This document is also updated to conform to current MIB conventions.

5. Relation to Interface Group (IF-MIB)

Since a router can be participating in VRRP on one or more interfaces, "ifIndex" is used as an index into the tables defined in the VRRP MIB. This MIB module imports ifIndex from the IF-MIB. At this time, the latest version of the IF-MIB is from RFC 2863 [RFC2863].

6. Multi-Stack Implementations

This MIB module is designed to support multi-stack implementations that run VRRP over IPv4 and IPv6. The IP version, Virtual Router Identifier (VRID), and ifIndex are used to uniquely identify rows in a multi-stack implementation.

7. Interpretation of RFC 5798

During the review of this document, it emerged that there are different possible interpretations of [RFC5798]. The authors of that document and the VRRP working group were unable to reach consensus as to which interpretation is correct. This document makes the following assumption:

IPv4 and IPv6 virtual routers are treated as two separate logical entities and represented as two separate entries in the `vrpv3OperationsTable`. This is required due to the undefined behavior of the protocol in [RFC5798] in a multi-stack scenario.

8. VRRP MIB Structure and Design

This MIB module contains three tables:

- (1) The `vrpv3OperationsTable` contains objects that define the operational characteristics of a VRRP router. Rows in this table correspond to instances of virtual routers.
- (2) The `vrpv3StatisticsTable` contains the operating statistics for a VRRP router.
- (3) The `vrpv3AssociatedIpAddrTable` contains the addresses of the virtual router(s) that a given VRRP router is backing up.

Tables are indexed on `ifIndex`, `VRID`, and the IP version to uniquely identify a VRRP router.

Notifications in this MIB module are controlled using the mechanisms defined in [RFC3413].

9. VRRP Multi-Stack Scenario

The following section provides examples of how some of the objects in this MIB are instantiated.

KEY:

The labels in the following tables and diagrams correspond to the actual MIB objects as follows:

```

if          = IfIndex
AddrType=  vrrpv3OperationsInetAddrType
VrId       = vrrpv3OperationsVrId
State      = vrrpv3OperationsStatus
Prior      = vrrpv3OperationsPriority
IpAddr     = vrrpv3OperationsMasterIpAddr

```

The following figure shows a hypothetical network with two VRRP routers, VR1 & VR2, configured with two virtual routers. Addresses in '()' indicate the address of the default gateway for a given host; H1 to H4 are IPv4 hosts, and H5 to H8 are IPv6 hosts. A, B, and C are IPv4 addresses, and X, Y, and Z are IPv6 addresses. In the diagram, "Interface" is used in the context defined in IF-MIB.

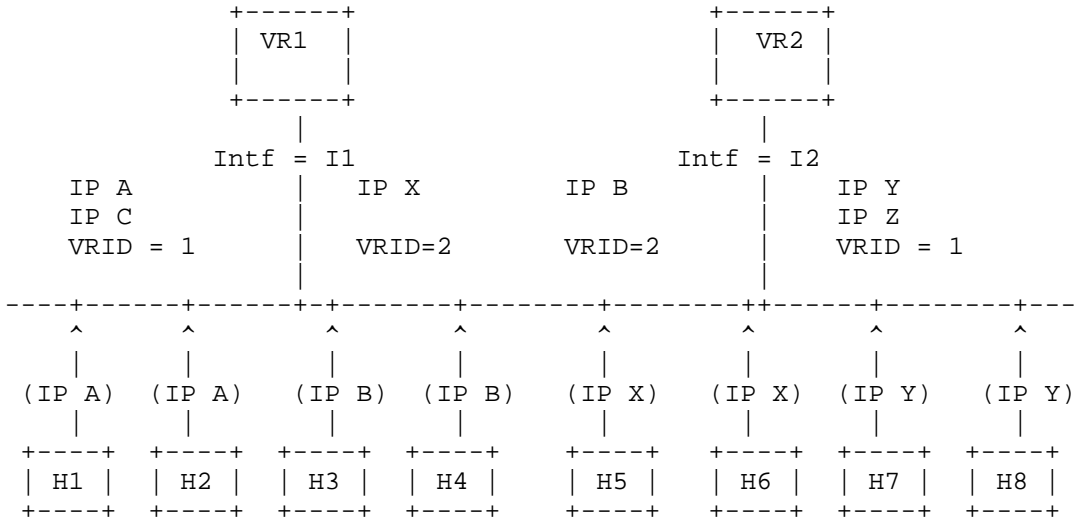

----- MIB Tables For VRRP Router "VR1": -----

vrrpv3OperationsTable

if	VrId	AddrType	State	Prior	IpAddr	
I1	01	1	M	255	A	(..)
I1	01	2	B	1-254	Y	(..)
I1	02	1	B	1-254	B	(..)
I1	02	2	M	255	X	(..)

vrrpv3AssociatedIpAddrTable

```

-----
| if | VrId | AddrType | IP   | RowStat |
+---+---+---+---+---+
| I1 | 01   | 1       | A   | active  |
+---+---+---+---+---+
| I1 | 01   | 1       | C   | active  |
+---+---+---+---+---+
| I1 | 01   | 2       | Y   | active  |
+---+---+---+---+---+
| I1 | 01   | 2       | Z   | active  |
+---+---+---+---+---+
| I1 | 02   | 1       | B   | active  |
+---+---+---+---+---+
| I1 | 02   | 2       | X   | active  |
+---+---+---+---+---+

```

----- MIB Tables For VRRP Router "VR2": -----

vrrpv3OperationsTable

```

-----
| if | VrId | AddrType | State | Prior | IpAddr |
+---+---+---+---+---+---+---+
| I2 | 01   | 1       | B   | 1-254 | A   |
+---+---+---+---+---+---+---+
| I2 | 01   | 2       | M   | 255   | Y   |
+---+---+---+---+---+---+---+
| I2 | 02   | 1       | M   | 255   | B   |
+---+---+---+---+---+---+---+
| I2 | 02   | 2       | B   | 1-254 | X   |
+---+---+---+---+---+---+---+

```

vrrpv3AssociatedIpAddrTable

```

-----
| if | VrId | AddrType | IP   | RowStat |
+---+---+---+---+---+
| I2 | 01   | 1       | A   | active  |
+---+---+---+---+---+
| I2 | 01   | 1       | C   | active  |
+---+---+---+---+---+
| I2 | 01   | 2       | Y   | active  |
+---+---+---+---+---+
| I2 | 01   | 2       | Z   | active  |
+---+---+---+---+---+
| I2 | 02   | 1       | B   | active  |
+---+---+---+---+---+
| I2 | 02   | 2       | X   | active  |
+---+---+---+---+---+

```

NOTES:

- 1) For "State": M = Master; B = Backup.
 In the vrrpv3OperationsTable, a "priority" of 255 indicates that the respective router owns the IP address, e.g., this IP address is native to the router (i.e., "the IP Address Owner").

10. Definitions

This MIB module makes reference to the following documents [RFC2578], [RFC2579], [RFC2580], [RFC2863], and [RFC4001].

VRRPV3-MIB DEFINITIONS ::= BEGIN

IMPORTS

```

MODULE-IDENTITY, OBJECT-TYPE,
NOTIFICATION-TYPE, Counter32,
Integer32, mib-2, Unsigned32,
Counter64, TimeTicks
    FROM SNMPv2-SMI                -- RFC2578

TEXTUAL-CONVENTION, RowStatus,
MacAddress, TruthValue, TimeStamp,
TimeInterval
    FROM SNMPv2-TC                -- RFC2579

MODULE-COMPLIANCE, OBJECT-GROUP,
NOTIFICATION-GROUP
    FROM SNMPv2-CONF              -- RFC2580

```

```

ifIndex
  FROM IF-MIB                                -- RFC2863
InetAddressType, InetAddress
  FROM INET-ADDRESS-MIB;                    -- RFC4001

```

```

vrrpv3MIB MODULE-IDENTITY
  LAST-UPDATED "201202130000Z"              -- Feb 13, 2012
  ORGANIZATION "IETF VRRP Working Group"
  CONTACT-INFO
    "WG E-Mail: vrrp@ietf.org"

```

```

  Editor:   Kalyan Tata
            Nokia
            313 Fairchild Dr,
            Mountain View, CA 94043
            Tata_kalyan@yahoo.com"

```

DESCRIPTION

"This MIB describes objects used for managing Virtual Router Redundancy Protocol version 3 (VRRPv3).

Copyright (c) 2012 IETF Trust and the persons identified as authors of the code. All rights reserved.

Redistribution and use in source and binary forms, with or without modification, is permitted pursuant to, and subject to the license terms contained in, the Simplified BSD License set forth in Section 4.c of the IETF Trust's Legal Provisions Relating to IETF Documents (<http://trustee.ietf.org/license-info>).

This version of the MIB module is part of RFC 6527. Please see the RFC for full legal notices."

```

REVISION "201202120000Z"                    -- Feb 13, 2012
DESCRIPTION "Initial version as published in RFC 6527."

```

```
 ::= { mib-2 207 }

```

```
-- Textual Conventions
```

```

Vrrpv3VrIdTC ::= TEXTUAL-CONVENTION
  DISPLAY-HINT "d"
  STATUS      current
  DESCRIPTION

```

"The value of the Virtual Router Identifier noted as (VRID) in RFC 5798. This, along with interface index (ifIndex) and IP version, serves to uniquely identify a virtual router on a given VRRP router."
 REFERENCE "RFC 5798 (Sections 3 and 5.2.3)"
 SYNTAX Integer32 (1..255)

-- VRRPv3 MIB Groups

```

vrrpv3Notifications OBJECT IDENTIFIER ::= { vrrpv3MIB 0 }
vrrpv3Objects        OBJECT IDENTIFIER ::= { vrrpv3MIB 1 }
vrrpv3Conformance   OBJECT IDENTIFIER ::= { vrrpv3MIB 2 }

```

-- VRRPv3 MIB Objects

```

vrrpv3Operations    OBJECT IDENTIFIER ::= { vrrpv3Objects 1 }
vrrpv3Statistics    OBJECT IDENTIFIER ::= { vrrpv3Objects 2 }

```

-- VRRPv3 Operations Table

vrrpv3OperationsTable OBJECT-TYPE

SYNTAX SEQUENCE OF Vrrpv3OperationsEntry

MAX-ACCESS not-accessible

STATUS current

DESCRIPTION

"Unified Operations table for a VRRP router that consists of a sequence (i.e., one or more conceptual rows) of 'vrrpv3OperationsEntry' items each of which describe the operational characteristics of a virtual router."

::= { vrrpv3Operations 1 }

vrrpv3OperationsEntry OBJECT-TYPE

SYNTAX Vrrpv3OperationsEntry

MAX-ACCESS not-accessible

STATUS current

DESCRIPTION

"An entry in the vrrpv3OperationsTable containing the operational characteristics of a virtual router. On a VRRP router, a given virtual router is identified by a combination of ifIndex, VRID, and the IP version. ifIndex represents an interface of the router.

A row must be created with vrrpv3OperationsStatus set to initialize(1) and cannot transition to backup(2) or master(3) until

vrrpv3OperationsRowStatus is transitioned to active(1).

The information in this table is persistent and when written the entity SHOULD save the change to non-volatile storage."

```
INDEX      { ifIndex, vrrpv3OperationsVrId,
              vrrpv3OperationsInetAddrType
            }
 ::= { vrrpv3OperationsTable 1 }
```

Vrrpv3OperationsEntry ::=

```
SEQUENCE {
  vrrpv3OperationsVrId
    Vrrpv3VrIdTC,
  vrrpv3OperationsInetAddrType
    InetAddressType,
  vrrpv3OperationsMasterIpAddr
    InetAddress,
  vrrpv3OperationsPrimaryIpAddr
    InetAddress,
  vrrpv3OperationsVirtualMacAddr
    MacAddress,
  vrrpv3OperationsStatus
    INTEGER,
  vrrpv3OperationsPriority
    Unsigned32,
  vrrpv3OperationsAddrCount
    Integer32,
  vrrpv3OperationsAdvInterval
    TimeInterval,
  vrrpv3OperationsPreemptMode
    TruthValue,
  vrrpv3OperationsAcceptMode
    TruthValue,
  vrrpv3OperationsUpTime
    TimeTicks,
  vrrpv3OperationsRowStatus
    RowStatus
}
vrrpv3OperationsVrId OBJECT-TYPE
SYNTAX      Vrrpv3VrIdTC
MAX-ACCESS  not-accessible
STATUS      current
DESCRIPTION
```

"This object contains the Virtual Router Identifier (VRID)."

REFERENCE "RFC 4001"

::= { vrrpv3OperationsEntry 1 }

vrrpv3OperationsInetAddrType OBJECT-TYPE

SYNTAX InetAddressType

MAX-ACCESS not-accessible

STATUS current

DESCRIPTION

"The IP address type of Vrrpv3OperationsEntry and Vrrpv3AssociatedIpAddrEntry. This value determines the type for vrrpv3OperationsMasterIpAddr, vrrpv3OperationsPrimaryIpAddr, and vrrpv3AssociatedIpAddrAddress.

ipv4(1) and ipv6(2) are the only two values supported in this MIB module."

REFERENCE "RFC 4001"

::= { vrrpv3OperationsEntry 2 }

vrrpv3OperationsMasterIpAddr OBJECT-TYPE

SYNTAX InetAddress

MAX-ACCESS read-only

STATUS current

DESCRIPTION

"The master router's real IP address. The master router would set this address to vrrpv3OperationsPrimaryIpAddr while transitioning to master state. For backup routers, this is the IP address listed as the source in the VRRP advertisement last received by this virtual router."

REFERENCE "RFC 5798"

::= { vrrpv3OperationsEntry 3 }

vrrpv3OperationsPrimaryIpAddr OBJECT-TYPE

SYNTAX InetAddress

MAX-ACCESS read-create

STATUS current

DESCRIPTION

"In the case where there is more than one IP Address (associated IP addresses) for a given 'ifIndex', this object is used to specify the IP address that will become the vrrpv3OperationsMasterIpAddr', should the virtual router transition from backup state to master."

::= { vrrpv3OperationsEntry 4 }

vrrpv3OperationsVirtualMacAddr OBJECT-TYPE

SYNTAX MacAddress
 MAX-ACCESS read-only
 STATUS current

DESCRIPTION

"The virtual MAC address of the virtual router. Although this object can be derived from the 'vrrpv3OperationsVrId' object, it is defined so that it is easily obtainable by a management application and can be included in VRRP-related SNMP notifications."

::= { vrrpv3OperationsEntry 5 }

vrrpv3OperationsStatus OBJECT-TYPE

SYNTAX INTEGER {
 initialize(1),
 backup(2),
 master(3)

}

MAX-ACCESS read-only
 STATUS current

DESCRIPTION

"The current state of the virtual router. This object has three defined values:

- 'initialize', which indicates that the virtual router is waiting for a startup event.
- 'backup', which indicates that the virtual router is monitoring the availability of the master router.
- 'master', which indicates that the virtual router is forwarding packets for IP addresses that are associated with this router."

REFERENCE "RFC 5798"

::= { vrrpv3OperationsEntry 6 }

vrrpv3OperationsPriority OBJECT-TYPE

SYNTAX Unsigned32 (0..255)
 MAX-ACCESS read-create
 STATUS current

DESCRIPTION

"This object specifies the priority to be used for the virtual router master election process; higher values imply higher priority.

A priority of '0', although not settable, is sent by the master router to indicate that this router has

ceased to participate in VRRP, and a backup virtual router should transition to become a new master.

A priority of 255 is used for the router that owns the associated IP address(es) for VRRP over IPv4 and hence is not settable.

Setting the values of this object to 0 or 255 should be rejected by the agents implementing this MIB module. For example, an SNMP agent would return 'badValue(3)' when a user tries to set the values 0 or 255 for this object."

```
REFERENCE "RFC 5798, Section 6.1"
DEFVAL    { 100 }
 ::= { vrrpv3OperationsEntry 7 }
```

vrrpv3OperationsAddrCount OBJECT-TYPE

```
SYNTAX      Integer32 (0..255)
```

```
MAX-ACCESS  read-only
```

```
STATUS      current
```

```
DESCRIPTION
```

"The number of IP addresses that are associated with this virtual router. This number is equal to the number of rows in the vrrpv3AssociatedAddrTable that correspond to a given ifIndex/VRID/IP version."

```
REFERENCE "RFC 5798, Section 6.1"
```

```
 ::= { vrrpv3OperationsEntry 8 }
```

vrrpv3OperationsAdvInterval OBJECT-TYPE

```
SYNTAX      TimeInterval (1..4095)
```

```
UNITS       "centiseconds"
```

```
MAX-ACCESS  read-create
```

```
STATUS      current
```

```
DESCRIPTION
```

"The time interval, in centiseconds, between sending advertisement messages. Only the master router sends VRRP advertisements."

```
REFERENCE "RFC 5798, Section 6.1"
```

```
DEFVAL      { 100 }
```

```
 ::= { vrrpv3OperationsEntry 9 }
```

vrrpv3OperationsPreemptMode OBJECT-TYPE

```
SYNTAX      TruthValue
```

```
MAX-ACCESS  read-create
```

```
STATUS      current
```

```
DESCRIPTION
```

"Controls whether a higher priority virtual router will preempt a lower priority master."
 REFERENCE "RFC 5798, Section 6.1"
 DEFVAL { true }
 ::= { vrrpv3OperationsEntry 10 }

vrrpv3OperationsAcceptMode OBJECT-TYPE

SYNTAX TruthValue
 MAX-ACCESS read-create
 STATUS current
 DESCRIPTION
 "Controls whether a virtual router in master state will accept packets addressed to the address owner's IPv6 address as its own if it is not the IPv6 address owner. Default is false(2).
 This object is not relevant for rows representing VRRP over IPv4 and should be set to false(2)."
 DEFVAL { false }
 ::= { vrrpv3OperationsEntry 11 }

vrrpv3OperationsUpTime OBJECT-TYPE

SYNTAX TimeTicks
 MAX-ACCESS read-only
 STATUS current
 DESCRIPTION
 "This value represents the amount of time, in TimeTicks (hundredth of a second), since this virtual router (i.e., the 'vrrpv3OperationsStatus') transitioned out of 'initialize'.
 REFERENCE "RFC 5798, Section 6.1"
 ::= { vrrpv3OperationsEntry 12 }

vrrpv3OperationsRowStatus OBJECT-TYPE

SYNTAX RowStatus
 MAX-ACCESS read-create
 STATUS current
 DESCRIPTION
 "The RowStatus variable should be used in accordance to installation and removal conventions for conceptual rows.

 To create a row in this table, a manager sets this object to either createAndGo(4) or createAndWait(5). Until instances of all corresponding columns are appropriately configured, the value of the corresponding instance of the 'vrrpv3OperationsRowStatus' column will be read as notReady(3).

In particular, a newly created row cannot be made active(1) until (minimally) the corresponding instance of vrrpv3OperationsInetAddrType, vrrpv3OperationsVrId, and vrrpv3OperationsPrimaryIpAddr has been set, and there is at least one active row in the 'vrrpv3AssociatedIpAddrTable' defining an associated IP address.

notInService(2) should be used to administratively bring the row down.

A typical order of operation to add a row is:

1. Create a row in vrrpv3OperationsTable with createAndWait(5).
2. Create one or more corresponding rows in vrrpv3AssociatedIpAddrTable.
3. Populate the vrrpv3OperationsEntry.
4. Set vrrpv3OperationsRowStatus to active(1).

A typical order of operation to delete an entry is:

1. Set vrrpv3OperationsRowStatus to notInService(2).
2. Set the corresponding rows in vrrpv3AssociatedIpAddrTable to destroy(6) to delete the entry.
3. Set vrrpv3OperationsRowStatus to destroy(6) to delete the entry."

```
::= { vrrpv3OperationsEntry 13 }
```

```
-- VRRP Associated Address Table
```

```
vrrpv3AssociatedIpAddrTable OBJECT-TYPE
    SYNTAX          SEQUENCE OF Vrrpv3AssociatedIpAddrEntry
    MAX-ACCESS      not-accessible
    STATUS          current
    DESCRIPTION
        "The table of addresses associated with each virtual
         router."
    ::= { vrrpv3Operations 2 }
```

```
vrrpv3AssociatedIpAddrEntry OBJECT-TYPE
    SYNTAX          Vrrpv3AssociatedIpAddrEntry
    MAX-ACCESS      not-accessible
    STATUS          current
    DESCRIPTION
        "An entry in the table contains an IP address that is
         associated with a virtual router. The number of rows
         for a given IP version, VrID, and ifIndex will equal
         the number of IP addresses associated (e.g., backed up)
```

by the virtual router (equivalent to 'vrrpv3OperationsIpAddrCount').

Rows in the table cannot be modified unless the value of 'vrrpv3OperationsStatus' for the corresponding entry in the vrrpv3OperationsTable has transitioned to initialize(1).

The information in this table is persistent and when written the entity SHOULD save the change to non-volatile storage."

```
INDEX      { ifIndex, vrrpv3OperationsVrId,
              vrrpv3OperationsInetAddrType,
              vrrpv3AssociatedIpAddrAddress }
```

```
::= { vrrpv3AssociatedIpAddrTable 1 }
```

```
Vrrpv3AssociatedIpAddrEntry ::=
  SEQUENCE {
    vrrpv3AssociatedIpAddrAddress

        InetAddress,
    vrrpv3AssociatedIpAddrRowStatus
        RowStatus
  }
```

```
vrrpv3AssociatedIpAddrAddress OBJECT-TYPE
  SYNTAX      InetAddress (SIZE (0|4|16))
  MAX-ACCESS  not-accessible
  STATUS      current
  DESCRIPTION
    "The assigned IP addresses that a virtual router is
    responsible for backing up.

    The IP address type is determined by the value of
    vrrpv3OperationsInetAddrType in the index of this
    row."
  REFERENCE  "RFC 5798"
  ::= { vrrpv3AssociatedIpAddrEntry 1 }
```

```
vrrpv3AssociatedIpAddrRowStatus OBJECT-TYPE
  SYNTAX      RowStatus
  MAX-ACCESS  read-create
  STATUS      current
  DESCRIPTION
    "The row status variable, used according to
    installation and removal conventions for conceptual
```

rows. To create a row in this table, a manager sets this object to either createAndGo(4) or createAndWait(5). Setting this object to active(1) results in the addition of an associated address for a virtual router. Setting this object to notInService(2) results in administratively bringing down the row.

Destroying the entry or setting it to destroy(6) removes the associated address from the virtual router. The use of other values is implementation-dependent.

Implementations should not allow deletion of the last row corresponding to an active row in vrrpv3OperationsTable.

Refer to the description of vrrpv3OperationsRowStatus for typical row creation and deletion scenarios."
 ::= { vrrpv3AssociatedIpAddrEntry 2 }

-- VRRP Router Statistics

vrrpv3RouterChecksumErrors OBJECT-TYPE

SYNTAX Counter64
 MAX-ACCESS read-only
 STATUS current

DESCRIPTION

"The total number of VRRP packets received with an invalid VRRP checksum value.

Discontinuities in the value of this counter can occur at re-initialization of the management system, and at other times as indicated by the value of vrrpv3GlobalStatisticsDiscontinuityTime."

REFERENCE "RFC 5798, Section 5.2.8"
 ::= { vrrpv3Statistics 1 }

vrrpv3RouterVersionErrors OBJECT-TYPE

SYNTAX Counter64
 MAX-ACCESS read-only
 STATUS current

DESCRIPTION

"The total number of VRRP packets received with an unknown or unsupported version number.

Discontinuities in the value of this counter can occur at re-initialization of the management system, and at

other times as indicated by the value of
vrrpv3GlobalStatisticsDiscontinuityTime."

REFERENCE "RFC 5798, Section 5.2.1"
 ::= { vrrpv3Statistics 2 }

vrrpv3RouterVrIdErrors OBJECT-TYPE

SYNTAX Counter64

MAX-ACCESS read-only

STATUS current

DESCRIPTION

"The total number of VRRP packets received with a
VRID that is not valid for any virtual router on this
router.

Discontinuities in the value of this counter can occur
at re-initialization of the management system, and at
other times as indicated by the value of
vrrpv3GlobalStatisticsDiscontinuityTime."

REFERENCE "RFC 5798, Section 5.2.3"
 ::= { vrrpv3Statistics 3 }

vrrpv3GlobalStatisticsDiscontinuityTime OBJECT-TYPE

SYNTAX TimeStamp

MAX-ACCESS read-only

STATUS current

DESCRIPTION

"The value of sysUpTime on the most recent occasion at
which one of vrrpv3RouterChecksumErrors,
vrrpv3RouterVersionErrors, and vrrpv3RouterVrIdErrors
suffered a discontinuity.

If no such discontinuities have occurred since the last
re-initialization of the local management subsystem,
then this object contains a zero value."

::= { vrrpv3Statistics 4 }

-- VRRP Router Statistics Table

vrrpv3StatisticsTable OBJECT-TYPE

SYNTAX SEQUENCE OF Vrrpv3StatisticsEntry

MAX-ACCESS not-accessible

STATUS current

DESCRIPTION

"Table of virtual router statistics."

::= { vrrpv3Statistics 5 }

```

vrrpv3StatisticsEntry OBJECT-TYPE
    SYNTAX      Vrrpv3StatisticsEntry
    MAX-ACCESS  not-accessible
    STATUS      current
    DESCRIPTION
        "An entry in the table containing statistics
        information about a given virtual router."
    AUGMENTS   { vrrpv3OperationsEntry }
    ::= { vrrpv3StatisticsTable 1 }

```

```

Vrrpv3StatisticsEntry ::=
    SEQUENCE {
        vrrpv3StatisticsMasterTransitions
            Counter32,
        vrrpv3StatisticsNewMasterReason
            INTEGER,
        vrrpv3StatisticsRcvdAdvertisements
            Counter64,
        vrrpv3StatisticsAdvIntervalErrors
            Counter64,
        vrrpv3StatisticsIpTtlErrors
            Counter64,
        vrrpv3StatisticsProtoErrReason
            INTEGER,
        vrrpv3StatisticsRcvdPriZeroPackets
            Counter64,
        vrrpv3StatisticsSentPriZeroPackets
            Counter64,
        vrrpv3StatisticsRcvdInvalidTypePackets
            Counter64,
        vrrpv3StatisticsAddressListErrors
            Counter64,
        vrrpv3StatisticsPacketLengthErrors
            Counter64,
        vrrpv3StatisticsRowDiscontinuityTime
            TimeStamp,
        vrrpv3StatisticsRefreshRate
            Unsigned32
    }

```

```

vrrpv3StatisticsMasterTransitions OBJECT-TYPE
    SYNTAX      Counter32
    MAX-ACCESS  read-only
    STATUS      current
    DESCRIPTION
        "The total number of times that this virtual router's
        state has transitioned to master state."

```

Discontinuities in the value of this counter can occur at re-initialization of the management system, and at other times as indicated by the value of vrrpv3StatisticsRowDiscontinuityTime."

```
::= { vrrpv3StatisticsEntry 1 }
```

vrrpv3StatisticsNewMasterReason OBJECT-TYPE

```
SYNTAX      INTEGER {
    notMaster (0),
    priority  (1),
    preempted (2),
    masterNoResponse (3)
}
```

```
MAX-ACCESS  read-only
```

```
STATUS      current
```

DESCRIPTION

"This indicates the reason for the virtual router to transition to master state. If the virtual router never transitioned to master state, the value of this object is notMaster(0). Otherwise, this indicates the reason this virtual router transitioned to master state the last time. Used by vrrpv3NewMaster notification."

```
::= { vrrpv3StatisticsEntry 2 }
```

vrrpv3StatisticsRcvdAdvertisements OBJECT-TYPE

```
SYNTAX      Counter64
```

```
MAX-ACCESS  read-only
```

```
STATUS      current
```

DESCRIPTION

"The total number of VRRP advertisements received by this virtual router.

Discontinuities in the value of this counter can occur at re-initialization of the management system, and at other times as indicated by the value of vrrpv3StatisticsRowDiscontinuityTime."

```
::= { vrrpv3StatisticsEntry 3 }
```

vrrpv3StatisticsAdvIntervalErrors OBJECT-TYPE

```
SYNTAX      Counter64
```

```
MAX-ACCESS  read-only
```

```
STATUS      current
```

DESCRIPTION

"The total number of VRRP advertisement packets received for which the advertisement interval is

different from the `vrpv3OperationsAdvInterval` configured on this virtual router.

Discontinuities in the value of this counter can occur at re-initialization of the management system, and at other times as indicated by the value of `vrpv3StatisticsRowDiscontinuityTime`."

```
::= { vrrpv3StatisticsEntry 4 }
```

```
vrrpv3StatisticsIpTtlErrors OBJECT-TYPE
```

```
SYNTAX Counter64
```

```
MAX-ACCESS read-only
```

```
STATUS current
```

```
DESCRIPTION
```

"The total number of VRRP packets received by the virtual router with IPv4 TTL (for VRRP over IPv4) or IPv6 Hop Limit (for VRRP over IPv6) not equal to 255.

Discontinuities in the value of this counter can occur at re-initialization of the management system, and at other times as indicated by the value of `vrpv3StatisticsRowDiscontinuityTime`."

```
REFERENCE "RFC 5798, Section 5.1.1.3"
```

```
::= { vrrpv3StatisticsEntry 5 }
```

```
vrrpv3StatisticsProtoErrReason OBJECT-TYPE
```

```
SYNTAX INTEGER {
```

```
noError (0),
```

```
ipTtlError (1),
```

```
versionError (2),
```

```
checksumError (3),
```

```
vrIdError(4)
```

```
}
```

```
MAX-ACCESS read-only
```

```
STATUS current
```

```
DESCRIPTION
```

"This indicates the reason for the last protocol error. This SHOULD be set to `noError(0)` when no protocol errors are encountered. Used by `vrpv3ProtoError` notification."

```
::= { vrrpv3StatisticsEntry 6 }
```

```
vrrpv3StatisticsRcvdPriZeroPackets OBJECT-TYPE
```

```
SYNTAX Counter64
```

```
MAX-ACCESS read-only
```

```
STATUS current
```

```
DESCRIPTION
```

"The total number of VRRP packets received by the virtual router with a priority of '0'.

Discontinuities in the value of this counter can occur at re-initialization of the management system, and at other times as indicated by the value of vrrpv3StatisticsRowDiscontinuityTime."

REFERENCE "RFC 5798, Section 5.2.4"

::= { vrrpv3StatisticsEntry 7 }

vrrpv3StatisticsSentPriZeroPackets OBJECT-TYPE

SYNTAX Counter64

MAX-ACCESS read-only

STATUS current

DESCRIPTION

"The total number of VRRP packets sent by the virtual router with a priority of '0'.

Discontinuities in the value of this counter can occur at re-initialization of the management system, and at other times as indicated by the value of vrrpv3StatisticsRowDiscontinuityTime."

REFERENCE "RFC 5798, Section 5.2.4"

::= { vrrpv3StatisticsEntry 8 }

vrrpv3StatisticsRcvdInvalidTypePackets OBJECT-TYPE

SYNTAX Counter64

MAX-ACCESS read-only

STATUS current

DESCRIPTION

"The number of VRRP packets received by the virtual router with an invalid value in the 'type' field.

Discontinuities in the value of this counter can occur at re-initialization of the management system, and at other times as indicated by the value of vrrpv3StatisticsRowDiscontinuityTime."

::= { vrrpv3StatisticsEntry 9 }

vrrpv3StatisticsAddressListErrors OBJECT-TYPE

SYNTAX Counter64

MAX-ACCESS read-only

STATUS current

DESCRIPTION

"The total number of packets received for which the address list does not match the locally configured list for the virtual router.

Discontinuities in the value of this counter can occur at re-initialization of the management system, and at other times as indicated by the value of vrrpv3StatisticsRowDiscontinuityTime."

```
::= { vrrpv3StatisticsEntry 10 }
```

```
vrrpv3StatisticsPacketLengthErrors OBJECT-TYPE
```

```
SYNTAX Counter64
```

```
MAX-ACCESS read-only
```

```
STATUS current
```

```
DESCRIPTION
```

"The total number of packets received with a packet length less than the length of the VRRP header.

Discontinuities in the value of this counter can occur at re-initialization of the management system, and at other times as indicated by the value of vrrpv3StatisticsRowDiscontinuityTime."

```
::= { vrrpv3StatisticsEntry 11 }
```

```
vrrpv3StatisticsRowDiscontinuityTime OBJECT-TYPE
```

```
SYNTAX TimeStamp
```

```
MAX-ACCESS read-only
```

```
STATUS current
```

```
DESCRIPTION
```

"The value of sysUpTime on the most recent occasion at which any one or more of this entry's counters suffered a discontinuity.

If no such discontinuities have occurred since the last re-initialization of the local management subsystem, then this object contains a zero value."

```
::= { vrrpv3StatisticsEntry 12 }
```

```
vrrpv3StatisticsRefreshRate OBJECT-TYPE
```

```
SYNTAX Unsigned32
```

```
UNITS "milliseconds"
```

```
MAX-ACCESS read-only
```

```
STATUS current
```

```
DESCRIPTION
```

"The minimum reasonable polling interval for this entry. This object provides an indication of the minimum amount of time required to update the counters in this entry."

```
::= { vrrpv3StatisticsEntry 13 }
```

```
-- Notification Definitions
```

```
-- Notifications may be controlled using SNMP-NOTIFICATION-MIB
```

```

vrrpv3NewMaster NOTIFICATION-TYPE
  OBJECTS      {
                vrrpv3OperationsMasterIpAddr,
                vrrpv3StatisticsNewMasterReason
              }
  STATUS       current
  DESCRIPTION
    "The newMaster notification indicates that the sending
    agent has transitioned to master state."
    ::= { vrrpv3Notifications 1 }

vrrpv3ProtoError NOTIFICATION-TYPE
  OBJECTS      {
                vrrpv3StatisticsProtoErrReason
              }
  STATUS       current
  DESCRIPTION
    "The notification indicates that the sending agent has
    encountered the protocol error indicated by
    vrrpv3StatisticsProtoErrReason."
    ::= { vrrpv3Notifications 2 }

-- Conformance Information

vrrpv3Compliances OBJECT IDENTIFIER ::= { vrrpv3Conformance 1 }
vrrpv3Groups      OBJECT IDENTIFIER ::= { vrrpv3Conformance 2 }

-- Compliance Statements

vrrpv3FullCompliance MODULE-COMPLIANCE
  STATUS current
  DESCRIPTION
    "The compliance statement"
  MODULE -- this module
  MANDATORY-GROUPS {
    vrrpv3OperationsGroup,
    vrrpv3StatisticsGroup,
    vrrpv3InfoGroup,
    vrrpv3NotificationsGroup
  }
  OBJECT          vrrpv3OperationsPriority
  WRITE-SYNTAX   Unsigned32 (1..254)
  DESCRIPTION    "Setable values are from 1 to 254."
  ::= { vrrpv3Compliances 1 }

vrrpv3ReadOnlyCompliance MODULE-COMPLIANCE
  STATUS current
  DESCRIPTION

```

"When this MIB module is implemented without support for read-create (i.e., in read-only mode), then such an implementation can claim read-only compliance. Such a device can then be monitored, but cannot be configured with this MIB."

```

MODULE -- this module
MANDATORY-GROUPS {
    vrrpv3OperationsGroup,
    vrrpv3StatisticsGroup,
    vrrpv3StatisticsDiscontinuityGroup,
    vrrpv3InfoGroup,
    vrrpv3NotificationsGroup
}

OBJECT      vrrpv3OperationsPriority
MIN-ACCESS  read-only
DESCRIPTION "Write access is not required."

OBJECT      vrrpv3OperationsPrimaryIpAddr
MIN-ACCESS  read-only
DESCRIPTION "Write access is not required."
OBJECT      vrrpv3OperationsAdvInterval
MIN-ACCESS  read-only
DESCRIPTION "Write access is not required."

OBJECT      vrrpv3OperationsPreemptMode
MIN-ACCESS  read-only
DESCRIPTION "Write access is not required."

OBJECT      vrrpv3OperationsAcceptMode
MIN-ACCESS  read-only
DESCRIPTION "Write access is not required."

OBJECT      vrrpv3OperationsRowStatus
MIN-ACCESS  read-only
DESCRIPTION "Write access is not required."

OBJECT      vrrpv3AssociatedIpAddrRowStatus
MIN-ACCESS  read-only
DESCRIPTION "Write access is not required."

 ::= { vrrpv3Compliances 2 }

```

-- Conformance Groups

```

vrrpv3OperationsGroup  OBJECT-GROUP
    OBJECTS {

```

```

    vrrpv3OperationsVirtualMacAddr,
    vrrpv3OperationsStatus,
    vrrpv3OperationsPriority,
    vrrpv3OperationsMasterIpAddr,
    vrrpv3OperationsAdvInterval,
    vrrpv3OperationsPreemptMode,
    vrrpv3OperationsAcceptMode,
    vrrpv3OperationsUpTime,
    vrrpv3OperationsRowStatus,
    vrrpv3OperationsAddrCount,
    vrrpv3OperationsPrimaryIpAddr,
    vrrpv3AssociatedIpAddrRowStatus
  }
STATUS current
DESCRIPTION
  "Conformance group for VRRPv3 operations."
 ::= { vrrpv3Groups 1 }

vrrpv3StatisticsGroup OBJECT-GROUP
OBJECTS {
  vrrpv3RouterChecksumErrors,
  vrrpv3RouterVersionErrors,
  vrrpv3RouterVrIdErrors,
  vrrpv3StatisticsMasterTransitions,
  vrrpv3StatisticsNewMasterReason,
  vrrpv3StatisticsRcvdAdvertisements,
  vrrpv3StatisticsAdvIntervalErrors,
  vrrpv3StatisticsRcvdPriZeroPackets,
  vrrpv3StatisticsSentPriZeroPackets,
  vrrpv3StatisticsRcvdInvalidTypePackets,
  vrrpv3StatisticsIpTtlErrors,
  vrrpv3StatisticsProtoErrReason,
  vrrpv3StatisticsAddressListErrors,
  vrrpv3StatisticsPacketLengthErrors,
  vrrpv3StatisticsRowDiscontinuityTime,
  vrrpv3StatisticsRefreshRate
}
STATUS current
DESCRIPTION
  "Conformance group for VRRPv3 statistics."
 ::= { vrrpv3Groups 2 }

vrrpv3StatisticsDiscontinuityGroup OBJECT-GROUP
OBJECTS {
  vrrpv3GlobalStatisticsDiscontinuityTime
}
STATUS current
DESCRIPTION

```

```

    "Objects providing information about counter
    discontinuities."
 ::= { vrrpv3Groups 3 }

vrrpv3InfoGroup OBJECT-GROUP
  OBJECTS {
    vrrpv3StatisticsProtoErrReason,
    vrrpv3StatisticsNewMasterReason
  }
  STATUS current
  DESCRIPTION
    "Conformance group for objects contained in VRRPv3
    notifications."
 ::= { vrrpv3Groups 4 }

vrrpv3NotificationsGroup NOTIFICATION-GROUP
  NOTIFICATIONS {
    vrrpv3NewMaster,
    vrrpv3ProtoError
  }
  STATUS current
  DESCRIPTION
    "The VRRP MIB Notification Group."
 ::= { vrrpv3Groups 5 }

END

```

11. Security Considerations

There are a number of management objects defined in this MIB module with a MAX-ACCESS clause of read-write and/or read-create. Such objects may be considered sensitive or vulnerable in some network environments. The support for SET operations in a non-secure environment without proper protection can have a negative effect on network operations. These are the tables and objects and their sensitivity/vulnerability:

The objects `vrrpv3OperationsPriority`, `vrrpv3OperationsPrimaryIpAddr`, `vrrpv3OperationsAdvInterval`, `vrrpv3OperationsPreemptMode`, `vrrpv3OperationsAcceptMode`, `vrrpv3OperationsRowStatus`, and `vrrpv3AssociatedIpAddrRowStatus` possess the read-create attribute. Manipulation of these objects is capable of affecting the operation of a virtual router.

Examples of how these objects could adversely affect the operation of a virtual router include:

- o An unauthorized change to `vrpv3OperationsPriority` can affect the priority used in master election, resulting in this router either becoming master when it should not, or in some other router being elected by preference. While this will disrupt the operator's plans, it will only replicate the unfortunate failure of multiple routers, and any router that does become master will be capable of filling that role.
- o Modification of `vrpv3OperationsPrimaryIpAddr` would cause the configured router to take on an incorrect IP address if it becomes master, which would be potentially very disruptive to the network operation.
- o A malicious change to `vrpv3OperationsAdvInterval` could either result in the configured router flooding the network with advertisements when it becomes master, or the new master not advertising frequently enough such that some routers do not learn about the new master.
- o `vrpv3OperationsPreemptMode` controls whether this router will preempt another master router. Setting it inappropriately will at worse cause one router to be master against the operator's plans, but that router will still be qualified to operate as a master.
- o Setting the `vrpv3OperationsAcceptMode` could prevent an IPv6-capable VRRP router from accepting packets addressed to the address owner's IPv6 address as its own even if it is not the IPv6 address owner. Although the default for this object is `false(2)`, unauthorized setting of this object to `false` might restrict the function of some parts of the network.
- o The `vrpv3OperationsRowStatus` object that could be used to disable a virtual router. While there are other columns that, if changed, could disrupt operations, they cannot be changed without first changing the `RowStatus` object.

SNMP versions prior to SNMPv3 did not include adequate security. Even if the network itself is secure (for example by using IPsec), there is no control as to who on the secure network is allowed to access and GET/SET (read/change/create/delete) the objects in this MIB module.

Implementations MUST provide the security features described by the SNMPv3 framework (see [RFC3410]), including full support for authentication and privacy via the User-based Security Model (USM) [RFC3414] with the AES cipher algorithm [RFC3826]. Implementations MAY also provide support for the Transport Security Model (TSM)

[RFC5591] in combination with a secure transport such as SSH [RFC5592] or TLS/DTLS [RFC6353].

Further, deployment of SNMP versions prior to SNMPv3 is NOT RECOMMENDED. Instead, it is RECOMMENDED to deploy SNMPv3 and to enable cryptographic security. It is then a customer/operator responsibility to ensure that the SNMP entity giving access to an instance of this MIB module is properly configured to give access to the objects only to those principals (users) that have legitimate rights to indeed GET or SET (change/create/delete) them.

12. IANA Considerations

The MIB module in this document uses the following IANA-assigned OBJECT IDENTIFIER values recorded in the SMI Numbers registry:

Descriptor -----	OBJECT IDENTIFIER value -----
vrpv3MIB	{ mib-2 207 vrpv3MIB VRRPV3-MIB }

This document obsoletes RFC 2787. Therefore, IANA has deprecated value 68 under 'mib-2', which is assigned to VRRP-MIB.

13. Normative References

- [RFC2119] Bradner, S., "Key words for use in RFCs to Indicate Requirement Levels", BCP 14, RFC 2119, March 1997.
- [RFC2578] McCloghrie, K., Perkins, D., and J. Schoenwaelder, "Structure of Management Information Version 2 (SMIv2)", STD 58, RFC 2578, April 1999.
- [RFC2579] McCloghrie, K., Perkins, D., and J. Schoenwaelder, "Textual Conventions for SMIv2", STD 58, RFC 2579, April 1999.
- [RFC2580] McCloghrie, K., Perkins, D., and J. Schoenwaelder, "Conformance Statements for SMIv2", STD 58, RFC 2580, April 1999.
- [RFC2863] McCloghrie, K. and F. Kastenholz, "The Interfaces Group MIB", RFC 2863, June 2000.
- [RFC3413] Levi, D., Meyer, P., and B. Stewart, "Simple Network Management Protocol (SNMP) Applications", STD 62, RFC 3413, December 2002.

[RFC4001] Daniele, M., Haberman, B., Routhier, S., and J. Schoenwaelder, "Textual Conventions for Internet Network Addresses", RFC 4001, February 2005.

[RFC5798] Nadas, S., Ed., "Virtual Router Redundancy Protocol (VRRP) Version 3 for IPv4 and IPv6", RFC 5798, March 2010.

14. Informative References

[RFC2338] Knight, S., Weaver, D., Whipple, D., Hinden, R., Mitzel, D., Hunt, P., Higginson, P., Shand, M., and A. Lindem, "Virtual Router Redundancy Protocol", RFC 2338, April 1998.

[RFC2787] Jewell, B. and D. Chuang, "Definitions of Managed Objects for the Virtual Router Redundancy Protocol", RFC 2787, March 2000.

[RFC3410] Case, J., Mundy, R., Partain, D., and B. Stewart, "Introduction and Applicability Statements for Internet-Standard Management Framework", RFC 3410, December 2002.

[RFC3414] Blumenthal, U. and B. Wijnen, "User-based Security Model (USM) for version 3 of the Simple Network Management Protocol (SNMPv3)", STD 62, RFC 3414, December 2002.

[RFC3826] Blumenthal, U., Maino, F., and K. McCloghrie, "The Advanced Encryption Standard (AES) Cipher Algorithm in the SNMP User-based Security Model", RFC 3826, June 2004.

[RFC5591] Harrington, D. and W. Hardaker, "Transport Security Model for the Simple Network Management Protocol (SNMP)", RFC 5591, June 2009.

[RFC5592] Harrington, D., Salowey, J., and W. Hardaker, "Secure Shell Transport Model for the Simple Network Management Protocol (SNMP)", RFC 5592, June 2009.

[RFC6353] Hardaker, W., "Transport Layer Security (TLS) Transport Model for the Simple Network Management Protocol (SNMP)", RFC 6353, July 2011.

15. Acknowledgments

Kripakaran Karlekar and Brian Jewell helped in design and initial drafts of this specification. This specification is based on RFC 2787. The authors of RFC 2787 are Brian Jewell and David Chuang. The author would also like to thank Bert Wijnen, Dave Thaler, Joan Cucchiara, Mukesh Gupta, Steve Bates, Adrian Farrel, Ben Campbell and Joel M. Halpern for taking time to review the document and provide valuable guidance.

Author's Address

Srinivas Kalyan Tata
Nokia
313 Fairchild Dr.
Mountain View, CA 94043
EMail: Tata_kalyan@yahoo.com

