

Internet Research Task Force (IRTF)
Request for Comments: 6740
Category: Experimental
ISSN: 2070-1721

RJ Atkinson
Consultant
SN Bhatti
U. St Andrews
November 2012

Identifier-Locator Network Protocol (ILNP) Architectural Description

Abstract

This document provides an architectural description and the concept of operations for the Identifier-Locator Network Protocol (ILNP), which is an experimental, evolutionary enhancement to IP. This is a product of the IRTF Routing Research Group.

Status of This Memo

This document is not an Internet Standards Track specification; it is published for examination, experimental implementation, and evaluation.

This document defines an Experimental Protocol for the Internet community. This document is a product of the Internet Research Task Force (IRTF). The IRTF publishes the results of Internet-related research and development activities. These results might not be suitable for deployment. This RFC represents the individual opinion(s) of one or more members of the Routing Research Group of the Internet Research Task Force (IRTF). Documents approved for publication by the IRSG are not a candidate for any level of Internet Standard; see Section 2 of RFC 5741.

Information about the current status of this document, any errata, and how to provide feedback on it may be obtained at <http://www.rfc-editor.org/info/rfc6740>.

Copyright Notice

Copyright (c) 2012 IETF Trust and the persons identified as the document authors. All rights reserved.

This document is subject to BCP 78 and the IETF Trust's Legal Provisions Relating to IETF Documents (<http://trustee.ietf.org/license-info>) in effect on the date of publication of this document. Please review these documents carefully, as they describe your rights and restrictions with respect to this document.

This document may not be modified, and derivative works of it may not be created, except to format it for publication as an RFC or to translate it into languages other than English.

Table of Contents

1. Introduction	3
1.1. Document Roadmap	5
1.2. History	6
1.3. Terminology	7
2. Architectural Overview	7
2.1. Identifiers and Locators	7
2.2. Deprecating IP Addresses	9
2.3. Session Terminology	10
2.4. Other Goals	12
3. Architectural Changes Introduced by ILNP	12
3.1. Identifiers	12
3.2. Locators	14
3.3. IP Address and Identifier-Locator Vector (I-LV)	16
3.4. Notation	16
3.5. Transport-Layer State and Transport Pseudo-Headers	18
3.6. Rationale for This Document	18
3.7. ILNP Multicasting	19
4. ILNP Basic Connectivity	20
4.1. Basic Local Configuration	20
4.2. I-L Communication Cache	21
4.3. Packet Forwarding	22
4.4. Packet Routing	23
5. Multihoming and Multi-Path Transport	24
5.1. Host Multihoming (H-MH)	25
5.2. Support for Multi-Path Transport Protocols	27
5.3. Site Multihoming (S-MH)	28
5.4. Multihoming Requirements for Site Border Routers	29
6. Mobility	30
6.1. Mobility / Multihoming Duality in ILNP	31
6.2. Host Mobility	32

6.3. Network Mobility	34
6.4. Mobility Requirements for Site Border Routers	36
6.5. Mobility with Multiple SBRs	36
7. IP Security for ILNP	36
7.1. Adapting IP Security for ILNP	37
7.2. Operational Use of IP Security with ILNP	37
8. Backwards Compatibility and Incremental Deployment	38
9. Security Considerations	39
9.1. Authentication of Locator Updates	39
9.2. Forged Identifier Attacks	40
9.3. IP Security Enhancements	42
9.4. DNS Security	42
9.5. Firewall Considerations	42
9.6. Neighbour Discovery Authentication	42
9.7. Site Topology Obfuscation	43
10. Privacy Considerations	43
10.1. Location Privacy	43
10.2. Identity Privacy	44
11. References	45
11.1. Normative References	45
11.2. Informative References	47
12. Acknowledgements	53

1. Introduction

This document is part of the ILNP document set, which has had extensive review within the IRTF Routing RG. ILNP is one of the recommendations made by the RG Chairs. Separately, various refereed research papers on ILNP have also been published during this decade. So, the ideas contained herein have had much broader review than the IRTF Routing RG. The views in this document were considered controversial by the Routing RG, but the RG reached a consensus that the document still should be published. The Routing RG has had remarkably little consensus on anything, so virtually all Routing RG outputs are considered controversial.

At present, the Internet research and development community is exploring various approaches to evolving the Internet Architecture to solve a variety of issues including, but not limited to, scalability of inter-domain routing [RFC4984]. A wide range of other issues (e.g., site multihoming, node multihoming, site/subnet mobility, node mobility) are also active concerns at present. Several different classes of evolution are being considered by the Internet research and development community. One class is often called "Map and Encapsulate", where traffic would be mapped and then tunnelled through the inter-domain core of the Internet. Another class being

considered is sometimes known as "Identifier/Locator Split". This document relates to a proposal that is in the latter class of evolutionary approaches.

There has been substantial research relating to naming in the Internet through the years [IEN1] [IEN19] [IEN23] [IEN31] [IEN135] [RFC814] [RFC1498] [RFC2956]. Much of that research has indicated that binding the end-to-end transport-layer session state with a specific interface of a node at a specific location is undesirable, for example, creating avoidable issues for mobility, multihoming, and end-to-end security. More recently, mindful of that important prior work, and starting well before the Routing RG was re-chartered to focus on inter-domain routing scalability, the authors have been examining enhancements to certain naming aspects of the Internet Architecture. Separately, the Internet Architecture Board (IAB) recently considered the matter of Internet evolution, including naming [RFC6250].

Our ideas and progress so far are embodied in the ongoing definition of an experimental protocol that we call the Identifier-Locator Network Protocol (ILNP).

Links to relevant material are all available at:

<http://ilnp.cs.st-andrews.ac.uk/>

At the time of writing, the main body of peer-reviewed research from which the ideas in this and the accompanying documents draw is given in [LABH06], [ABH07a], [ABH07b], [ABH08a], [ABH08b], [ABH09a], [ABH09b], [RAB09], [ABH10], [RB10], [BA11], [BAK11], and [BA12].

In this document, we:

- a) describe the architectural concepts behind ILNP and how various ILNP capabilities operate: this document deliberately focuses on describing the key architectural changes that ILNP introduces and defers engineering discussion to separate documents.

Other documents (listed below):

- b) show how functions based on ILNP would be realised on today's Internet by proposing an instance of ILNP based on IPv6, which we call ILNPv6 (there is also a document describing ILNPv4, which is how ILNP could be applied to IPv4).
- c) discuss salient operational and engineering issues impacting the deployment of ILNPv6 and the impact on the Internet.

- d) give architectural descriptions of optional advanced capabilities in advanced deployments based on the ILNP approach.

1.1. Document Roadmap

This document describes the architecture for the Identifier-Locator Network Protocol (ILNP) including concept of operations. The authors recommend reading and understanding this document as the starting point to understanding ILNP.

The ILNP architecture can have more than one engineering instantiation. For example, one can imagine a "clean-slate" engineering design based on the ILNP architecture. In separate documents, we describe two specific engineering instances of ILNP. The term "ILNPv6" refers precisely to an instance of ILNP that is based upon, and backwards compatible with, IPv6. The term "ILNPv4" refers precisely to an instance of ILNP that is based upon, and backwards compatible with, IPv4.

Many engineering aspects common to both ILNPv4 and ILNPv6 are described in [RFC6741]. A full engineering specification for either ILNPv6 or ILNPv4 is beyond the scope of this document.

Readers are referred to other related ILNP documents for details not described here:

- a) [RFC6741] describes engineering and implementation considerations that are common to both ILNPv4 and ILNPv6.
- b) [RFC6742] defines additional DNS resource records that support ILNP.
- c) [RFC6743] defines a new ICMPv6 Locator Update message used by an ILNP node to inform its correspondent nodes of any changes to its set of valid Locators.
- d) [RFC6744] defines a new IPv6 Nonce Destination Option used by ILNPv6 nodes (1) to indicate to ILNP correspondent nodes (by inclusion within the initial packets of an ILNP session) that the node is operating in the ILNP mode and (2) to prevent off-path attacks against ILNP ICMP messages. This Nonce is used, for example, with all ILNP ICMPv6 Locator Update messages that are exchanged among ILNP correspondent nodes.
- e) [RFC6745] defines a new ICMPv4 Locator Update message used by an ILNP node to inform its correspondent nodes of any changes to its set of valid Locators.

- f) [RFC6746] defines a new IPv4 Nonce Option used by ILNPv4 nodes to carry a security nonce to prevent off-path attacks against ILNP ICMP messages and also defines a new IPv4 Identifier Option used by ILNPv4 nodes.
- g) [RFC6747] describes extensions to the Address Resolution Protocol (ARP) for use with ILNPv4.
- h) [RFC6748] describes optional engineering and deployment functions for ILNP. These are not required for the operation or use of ILNP and are provided as additional options.

1.2. History

In 1977, Internet researchers at University College London wrote the first Internet Experiment Note (IEN), which discussed issues with the interconnection of networks [IEN1]. This identified the inclusion of network-layer addresses in the transport-layer session state (e.g., TCP checksum) as a significant problem for mobile and multihomed nodes and networks. It also proposed separation of identity from location as a better approach to take when designing the TCP/IP protocol suite. Unfortunately, that separation did not occur, so the deployed IPv4 and IPv6 Internet entangles upper-layer protocols (e.g., TCP, UDP) with network-layer routing and topology information (e.g., IP Addresses) [IEN1] [RFC768] [RFC793].

The architectural concept behind ILNP derives from a June 1994 note by Bob Smart to the IETF SIPP WG mailing list [SIPP94]. In January 1995, Dave Clark sent a similar note to the IETF IPng WG mailing list, suggesting that the IPv6 address be split into separate Identifier and Locator fields [IPng95].

Afterwards, Mike O'Dell pursued this concept in Internet-Drafts describing "8+8" [8+8] and "GSE" (Global, Site, and End-system) [GSE]. More recently, the IRTF Namespace Research Group (NSRG) studied this matter around the turn of the century. Unusually for an IRTF RG, the NSRG operated on the principle that unanimity was required for the NSRG to make a recommendation. Atkinson was a member of the IRTF NSRG. At least one other protocol, the Host Identity Protocol (HIP), also derives in part from the IRTF NSRG studies (and related antecedent work). This current proposal differs from O'Dell's work in various ways, notably in that it does not require deployment or use of Locator rewriting.

The key idea proposed for ILNP is to directly and specifically change the overloaded semantics of the IP Address. The Internet community has indicated explicitly, several times, that this use of overloaded semantics is a significant problem with the use of the Internet protocol today [RFC1498] [RFC2101] [RFC2956] [RFC4984].

While the research community has made a number of proposals that could provide solutions, so far there has been little progress on changing the status quo.

1.3. Terminology

The key words "MUST", "MUST NOT", "REQUIRED", "SHALL", "SHALL NOT", "SHOULD", "SHOULD NOT", "RECOMMENDED", "MAY", and "OPTIONAL" in this document are to be interpreted as described in [RFC2119].

2. Architectural Overview

ILNP takes a different approach to naming of communication objects within the network stack. Two new data types are introduced which subsume the role of the IP Address at the network and transport layers in the current IP architecture.

2.1. Identifiers and Locators

ILNP explicitly replaces the use of IP Addresses with two distinct name spaces, each having distinct and different semantics:

- a) Identifier: a non-topological name for uniquely identifying a node.
- b) Locator: a topologically bound name for an IP subnetwork.

The use of these two new namespaces in comparison to IP is given in Table 1. The table shows where existing names are used for state information in end-systems or protocols.

Layer	IP	ILNP
Application	FQDN or IP Address	FQDN
Transport	IP Address	Identifier
Network	IP Address	Locator
Physical i/f	IP Address	MAC address

FQDN = Fully Qualified Domain Name

i/f = interface

MAC = Media Access Control

Table 1: Use of Names for State Information in Various Communication Layers for IP and ILNP

As shown in Table 1, if an application uses a Fully Qualified Domain Name at the application-layer, rather than an IP Address or other lower-layer identifier, then the application perceives no architectural difference between IP and ILNP. We call such applications "well-behaved" with respect to naming as use of the FQDN at the application-layer is recommended in [RFC1958]. Some other applications also avoid use of IP Address information within the application-layer protocol; we also consider these applications to be "well-behaved". Any well-behaved application should be able to operate on ILNP without any changes. Note that application-level use of IP Addresses includes application-level configuration information, e.g., Apache web server (httpd) configuration files make extensive use of IP Addresses as a form of identity.

ILNP does not require applications to be rewritten to use a new Networking Application Programming Interface (API). So existing well-behaved IP-based applications should be able to work over ILNP as is.

In ILNP, transport-layer protocols use only an end-to-end, non-topological node Identifier in any transport-layer session state. It is important to note that the node Identifier names the node, not a specific interface of the node. In this way, it has different semantics and properties than either the IPv4 address, the IPv6 address, or the IPv6 interface identifier [RFC791] [RFC4291].

The use of the ILNP Identifier value within application-layer protocols is not recommended. Instead, the use of either a FQDN or some different topology-independent namespace is recommended.

At the network-layer, Locator values, which have topological significance, are used for routing and forwarding of ILNP packets, but Locators are not used in upper-layer protocols.

As well as the new namespaces, another significant difference in ILNP, as shown in Table 1, is that there is no binding of a routable name to an interface, or Sub-Network Point of Attachment (SNPA), as there is in IP. The existence of such a binding in IP effectively binds transport protocol flows to a specific, single interface on a node. Also, applications that include IP Addresses in their application-layer session state effectively bind to a specific, single interface on a node [RFC2460] [RFC6724].

In ILNP, dynamic bindings exist between Identifier values and associated Locator values, as well as between {Identifier, Locator} pairs and (physical or logical) interfaces on the node.

This change enhances the Internet Architecture by adding crisp and clear semantics for the Identifier and for the Locator, removing the overloaded semantics of the IP Address [RFC1992] [RFC4984], by updating end-system protocols, but without requiring any router or backbone changes. In ILNP, the closest approximation to an IP Address is an I-L Vector (I-LV), which is a given binding between an Identifier and Locator pair, written as [I, L]. I-LVs are discussed in more detail below.

Where, today, IP packets have:

- Source IP Address, Destination IP Address

instead, ILNP packets have:

- source I-LV, destination I-LV

However, it must be emphasised that the I-LV and the IP Address are **not** equivalent.

With these naming enhancements, we will improve the Internet Architecture by adding explicit harmonised support for many functions, such as multihoming, mobility, and IPsec.

2.2. Deprecating IP Addresses

ILNP places an explicit Locator and Identifier in the IP packet header, replacing the usual IP Address. Locators are tied to the topology of the network. They may change frequently, as the node or site changes its network connectivity. The node Identifier is normally much more static and remains constant throughout the life of a given transport-layer session, and frequently much longer. However, there are various options for Identifier values, as discussed in [RFC6741]. The way that I-LVs are encoded into packet headers is different for IPv4 and IPv6, as explained in [RFC6741].

Identifiers and Locators for hosts are advertised explicitly in DNS, through the use of new Resource Records (RRs). This is a logical and reasonable use of DNS, completely analogous to the capability that DNS provides today. At present, among other current uses, the DNS is used to map from an FQDN to a set of addresses. As ILNP replaces IP Addresses with Identifiers and Locators, it is then clearly rational to use the DNS to map an FQDN to a set of Identifiers and a set of Locators for a node.

The presence of ILNP Locators and Identifiers in the DNS for a DNS owner name is an indicator to correspondents that the correspondents can try to establish an ILNP-based transport-layer session with that DNS owner name.

Specifically in response to [RFC4984], ILNP improves routing scalability by helping multihomed sites operate effectively with Provider Aggregated (PA) address prefixes. Many multihomed sites today request provider-independent (PI) address prefixes so they can provide session survivability despite the failure of one or more access links or Internet Service Providers (ISPs). ILNP provides this transport-layer session survivability by having a provider-independent Node Identifier (NID) value that is free of any topological semantics. This NID value can be bound dynamically to a Provider Aggregated Locator (L) value, the latter being a topological name, i.e., a PA network prefix. By allowing correspondents to change arbitrarily among multiple PA Locator values, survivability is enabled as changes to the L values need not disrupt transport-layer sessions. In turn, this allows an ILNP multihomed site to have both the full transport-layer and full network-layer session resilience that is today offered by PI addressing while using the equivalent of PA addressing. In turn, this eliminates the current need to use globally visible PI routing prefixes for each multihomed site.

2.3. Session Terminology

To improve clarity and readability of the several ILNP specification documents, this section defines the terms "network-layer session" and "transport-layer session" both for IP-based networks and ILNP-based networks.

Today, network-layer IP sessions have 2 components:

- Source IP Address (A_S)
- Destination IP Address (A_D)

For example, a tuple for an IP layer session would be:

<IP: A_S, A_D>

Instead, network-layer ILNP sessions have 4 components:

- Source Locator(s) (L_S)
- Source Identifier(s) (I_S)
- Destination Locator(s) (L_D)
- Destination Identifier(s) (I_D)

and a tuple for an ILNP session would be:

```
<ILNP: I_S, L_S, I_D, L_D>
```

The phrase "ILNP session" refers to an ILNP-based network-layer session, having the 4 components in the definition above.

For engineering efficiency, multiple transport-layer sessions between a pair of ILNP correspondents normally share a single ILNP session (I-LV pairs and associated Nonce values). Also, for engineering convenience (and to cope with situation where different nodes, at different locations, might use the same I values), in the specific implementation of ILNPv6 and ILNPv4, we define the use of nonce values:

- Source-to-destination Nonce value (N_S)
- Destination-to-source Nonce value (N_D)

These are explained in more detail in [RFC6741], with [RFC6744] for ILNPv6 and [RFC6746] for ILNPv4.

Today, transport-layer sessions using IP include these 5 components:

- Source IP Address (A_S)
- Destination IP Address (A_D)
- Transport-layer protocol (e.g., UDP, TCP, SCTP)
- Source transport-layer port number (P_S)
- Destination transport-layer port number (P_D)

For example, a TCP tuple would be:

```
<TCP: P_S, P_D, A_S, A_D>
```

Instead, transport-layer sessions using ILNP include these 5 components:

- Source Identifier (I_S)
- Destination Identifier (I_D)
- Transport-layer protocol (e.g., UDP, TCP, SCTP)
- Source transport-layer port number (P_S)
- Destination transport-layer port number (P_D)

and an example tuple:

```
<TCP: P_S, P_D, I_S, I_D>
```

2.4. Other Goals

While we seek to make significant enhancements to the current Internet Architecture, we also wish to ensure that instantiations of ILNP are:

- a) Backwards compatible: implementations of ILNP should be able to work with existing IPv6 or IPv4 deployments, without requiring application changes.
- b) Incrementally deployable: to deploy an implementation of ILNP, changes to the network nodes should only be for those nodes that choose to use ILNP. The use of ILNP by some nodes does not require other nodes (that do not use ILNP) to be upgraded.

3. Architectural Changes Introduced by ILNP

In this section, we describe the key changes that are made to the current Internet Architecture. These key changes impact end-systems, rather than routers.

3.1. Identifiers

Identifiers, also called Node Identifiers (NIDs), are non-topological values that identify an ILNP node. A node might be a physical node or a virtual node. For example, a single physical device might contain multiple independent virtual nodes. Alternately, a single virtual device might be composed from multiple physical devices. In the case of a Multi-Level Secure (MLS) system [DIA] [DoD85] [DoD87] [RFC5570], each valid Sensitivity Label of that system might be a separate virtual node.

A node MAY have multiple Identifier values associated with it, which MAY be used concurrently.

In normal operation, when a node is responding to a received ILNP packet that creates a new network-layer session, the correct NID value to use for that network-layer session with that correspondent node will be learned from the received ILNP packet.

In normal operation, when a node is initiating communication with a correspondent node, the correct I value to use for that session with that correspondent node will be learned either through the application-layer naming, through DNS name resolution, or through

some alternative name resolution system. Another option is an application may be able to select different I values directly -- as Identifiers are visible above the network layer via the transport protocol.

3.1.1. Node Identifiers Are Immutable during a Session

Once a Node Identifier (NID) value has been used to establish a transport-layer session, that Node Identifier value forms part of the end-to-end (invariant) transport-layer session state and so MUST remain fixed for the duration of that session. This means, for example, that throughout the duration of a given TCP session, the Source Node Identifier and Destination Node Identifier values will not change.

In normal operation, a node will not change its set of valid Identifier values frequently. However, a node MAY change its set of valid Identifier values over time, for example, in an effort to provide identity obfuscation, while remaining subject to the architectural rule of the preceding paragraph. When a node has more than one Node Identifier value concurrently, the node might have multiple concurrent ILNP sessions with some correspondent node, in which case Node Identifier values MAY differ between the different concurrent ILNP sessions.

3.1.2. Syntax

ILNP Identifiers have the same syntax as IPv6 interface identifiers [RFC4291], based on the EUI-64 format [IEEE-EUI], which helps with backwards compatibility. There is no semantic equivalent to an ILNP Identifier in IPv4 or IPv6 today.

The Modified EUI-64 syntax used by both ILNP Identifiers and IPv6 interface identifiers contains a bit indicating whether the value has global scope or local scope [IEEE-EUI] [RFC4291]. ILNP Identifiers have either global scope or local scope. If they have global scope, they SHOULD be globally unique.

Regardless of whether an Identifier is global scope or local scope, an Identifier MUST be unique within the scope of a given Locator value to which it is bound for a given ILNP session or packet flow. As an example, with ILNPv6, the ordinary IPv6 Neighbour Discovery (ND) processes ensure that this is true, just as ND ensures that no two IPv6 nodes on the same IPv6 subnetwork have the same IPv6 address at the same time.

Both the IEEE EUI-64 specification and the Modified EUI-64 syntax also has a 'Group' bit [IEEE-EUI] [RFC4291]. For both ILNP node Identifiers and also IPv6 interface identifiers, this Group bit is set to 0.

3.1.3. Semantics

Unicast ILNP Identifier values name the node, rather than naming a specific interface on that node. So ILNP Identifiers have different semantics than IPv6 interface identifiers.

3.2. Locators

Locators are topologically significant names, analogous to (sub)network routing prefixes. The Locator names the IP subnetwork that a node is connected to. ILNP neither prohibits nor mandates in-transit modification of Locator values.

A host MAY have several Locators at the same time, for example, if it has a single network interface connected to multiple subnetworks (e.g., VLAN deployments on wired Ethernet) or has multiple interfaces each on a different subnetwork. Locator values normally have Locator Preference Indicator (LPI) values associated with them. These LPIs indicate that a specific Locator value has higher or lower preference for use at a given time. Local LPI values may be changed through local policy or via management interfaces. Remote LPI values are normally learned from the DNS, but the local copy of a remote LPI value might be modified by local policy relating to preferred paths or prefixes.

Locator values are used only at the network layer. Locators are not used in end-to-end transport state. For example, Locators are not used in transport-layer session state or application-layer session state. However, this does not preclude an end-system setting up local dynamic bindings for a single transport flow to multiple Locator values concurrently.

The routing system only uses Locators, not Identifiers. For unicast traffic, ILNP uses longest-prefix match routing, just as the IP Internet does.

Section 4 below describes in more detail how Locators are used in forwarding and routing packets from a sending node on a source subnetwork to one or more receiving nodes on one or more destination subnetworks.

A difference from earlier proposals [GSE] [8+8] is that, in normal operation, the originating host supplies both Source Locator and Destination Locator values in the packets it sends out.

Section 4.3 describes packet forwarding in more detail, while Section 4.4 describes packet routing in more detail.

3.2.1. Locator Values Are Dynamic

The ILNP architecture recognises that Locator values are topologically significant, so the set of Locator values associated with a node normally will need to change when the node's connectivity to the Internet topology changes. For example, a mobile or multihomed node is likely to have connectivity changes from time to time, along with the corresponding changes to the set of Locator values.

When a node using a specific set of Locator values changes one or more of those Locator values, then the node (1) needs to update its local knowledge of its own Locator values, (2) needs to inform all active Correspondent Nodes (CNs) of those changes to its set of Locator values so that ILNP session continuity is maintained, and (3) if it expects incoming connections the node also needs to update its Locator-related entries in the Domain Name System. [RFC6741] describes the engineering and implementation details of this process.

3.2.2. Locator Updates

As Locator values can be dynamic, and they could change for a node during an ILNP session, correspondents need to be notified when a Locator value for a node changes for any existing ILNP session. To enable this, a node that sees its Locator values have changed MUST send a Locator Update (LU) message to its correspondent nodes. The details of this procedure are discussed in other ILNP documents -- [RFC6741], [RFC6743], and [RFC6745]. (The change in Locator values may also need to be notified to DNS but that is discussed elsewhere.)

3.2.3. Syntax

ILNP Locators have the same syntax as an IP unicast routing prefix.

3.2.4. Semantics

ILNP unicast Locators have the same semantics as an IP unicast routing prefix, since they name a specific subnetwork. ILNP neither prohibits nor requires in-transit modification of Locator values.

3.3. IP Address and Identifier-Locator Vector (I-LV)

Historically, an IP Address has been considered to be an atomic datum, even though it is recognised that an IP Address has an internal structure: the network prefix plus either the host ID (IPv4) or the interface identifier (IPv6). However, this internal structure has not been used in end-system protocols; instead, all the bits of the IP Address are used. (Additionally, in IPv4 the IPv4 subnet mask uses bits from the host ID, a further confusion of the structure, even though it is an extremely useful engineering mechanism.)

In ILNP, the IP Address is replaced by an "Identifier-Locator Vector" (I-LV). This consists of a pairing of an Identifier value and a Locator value for that packet, written as [I, L]. All ILNP packets have Source Identifier, Source Locator, Destination Identifier, and Destination Locator values. The I value of the I-LV is used by upper-layer protocols (e.g., TCP, UDP, SCTP), so needs to be immutable. Locators are not used by upper-layer protocols (e.g., TCP, UDP, SCTP). Instead, Locators are similar to IP routing prefixes, and are only used to name a specific subnetwork.

While it is possible to say that an I-LV is an approximation to an IP Address of today, it should be understood that an I-LV:

- a) is not an atomic datum, being a pairing of two data types, an Identifier and a Locator.
- b) has different semantics and properties to an IP Address, as is described in this document.

In our discussion, it will be convenient sometimes to refer to an I-LV, but sometimes to refer only to an Identifier value, or only to a Locator value.

ILNP packets always contain a source I-LV and a destination I-LV.

3.4. Notation

In describing how capabilities are implemented in ILNP, we will consider the differences in end-systems' state between IP and ILNP in order to highlight the architectural changes.

We define a formal notation to represent the data contained in the transport-layer session state. We define:

A = IP Address
 I = Identifier
 L = Locator
 P = Transport-layer port number

To differentiate the local and remote values for the above items, we also use suffixes, for example:

_L = local
_R = remote

With IPv4 and IPv6 today, the invariant state at the transport-layer for TCP can be represented by the tagged tuple:

<TCP: A_L, A_R, P_L, P_R> --- (1)

Tag values that will be used are:

IP Internet Protocol
 ILNP Identifier-Locator Network Protocol
 TCP Transmission Control Protocol
 UDP User Datagram Protocol

So, for example, with IP, a UDP packet would have the tagged tuple:

<UDP: A_L, A_R, P_L, P_R> --- (2)

A TCP segment carried in an IP packet may be represented by the tagged tuple binding:

<TCP: A_L, A_R, P_L, P_R><IP: A_L, A_R> --- (3)

and a UDP packet would have the tagged tuple binding:

<UDP: A_L, A_R, P_L, P_R><IP: A_L, A_R> --- (4)

In ILNP, the transport-layer state for TCP is:

<TCP: I_L, I_R, P_L, P_R> --- (5)

The binding for a TCP segment within an ILNP packet:

<TCP: I_L, I_R, P_L, P_R><ILNP: L_L, L_R> --- (6)

When comparing tuple expressions (3) and (6), we see that for IP, any change to network addresses impacts the end-to-end state, but for ILNP, changes to Locator values do not impact end-to-end state. This provides end-system session state invariance, a key feature of ILNP compared to IP as it is used in some situations today. ILNP adopts the end-to-end approach for its architecture [SRC84]. As noted previously, nodes MAY have more than one Locator concurrently, and nodes MAY change their set of active Locator values as required.

While these documents do not include SCTP examples, the same notation can be used, simply substituting the string "SCTP" for the string "TCP" or the string "UDP" in the above examples.

3.5. Transport-Layer State and Transport Pseudo-Headers

In ILNP, protocols above the network layer do not use the Locator values. Thus, the transport layer uses only the I values for the transport-layer session state (e.g., TCP pseudo-header checksum, UDP pseudo-header checksum), as is shown, for example, in expression (6) above.

Additionally, from a practical perspective, while the I values are only used in protocols above the network layer, it is convenient for them to be carried in network packets, so that the namespace for the I values can be used by any transport-layer protocols operating above the common network layer.

3.6. Rationale for This Document

This document provides an architectural description of the core ILNP capabilities and functions. It is based around the use of example scenarios so that practical issues can be highlighted.

In some cases, illustrative suggestions and light discussion are presented with respect to engineering issues, but detailed discussion of engineering issues are deferred to other ILNP documents.

The order of the examples presented below is intended to allow an incremental technical understanding of ILNP to be developed. There is no other reason for the ordering of the examples listed below.

Many of the descriptions are based on the use of an example site network as shown in Figure 3.1.

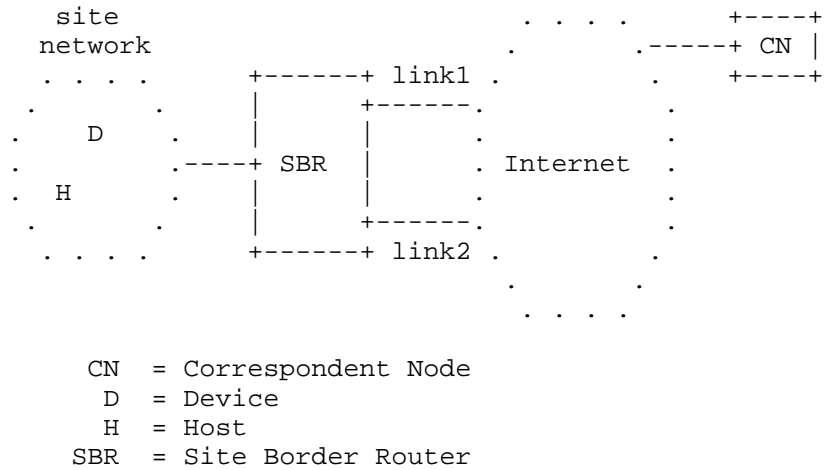

Figure 3.1: A Simple Site Network for ILNP Examples

In some cases, hosts (H) or devices (D) act as end-systems within the site network, and communicate with (one or more) Correspondent Node (CN) instances that are beyond the site.

Note that the figure is illustrative and presents a logical view. For example, the CN may itself be on a site network, just like H or D.

Also, for formulating examples, we assume ILNPv6 is in use, which has the same packet header format (as viewed by routers) as IPv6, and can be seen as a superset of IPv6 capabilities.

For simplicity, we assume that name resolution is via the deployed DNS, which has been updated to store DNS records for ILNP [RFC6742].

Note that, from an engineering viewpoint, this does NOT mean that the DNS also has to be ILNP capable: existing IPv4 or IPv6 infrastructure can be used for DNS transport.

3.7. ILNP Multicasting

Multicast forwarding and routing are unchanged, in order to avoid requiring changes in deployed IP routers and routing protocols. ILNPv4 multicasting is the same as IETF Standards Track IPv4 multicasting [RFC1112] [RFC3376]. ILNPv6 multicasting is the same as IETF Standards Track IPv6 multicasting [RFC4291] [RFC2710] [RFC3810].

4. ILNP Basic Connectivity

In this section, we describe basic packet forwarding and routing in ILNP. We highlight areas where it is similar to current IP, and also where it is different from current IP. We use examples in order to illustrate the intent and show the feasibility of the approach.

For this section, in Figure 4.1, H is a fixed host in a simple site network, and CN is a remote Correspondent Node outside the site; H and CN are ILNP-capable, while the Site Border Router (SBR) does not need to be ILNP-capable.

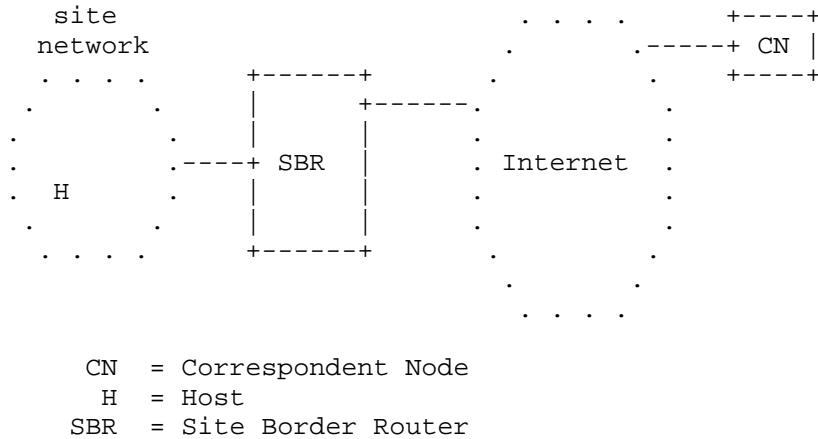

Figure 4.1: A Simple Site Network for ILNP Examples

4.1. Basic Local Configuration

This section uses the term "address management", in recognition of the analogy with capabilities present in IP today. In this document, address management is about enabling hosts to attach to a subnetwork and enabling network-layer communication between and among hosts, also including:

- a) enabling identification of a node within a site.
- b) allowing basic routing/forwarding from a node acting as an end-system.

If we consider Figure 4.1, imagine that host H has been connected to the site network. Administratively, it needs at least one I value and one L value in order to be able to communicate.

Today, local administrative procedures allocate IP Addresses, often using various protocol mechanisms (e.g., NETCONF-based router configuration, DHCP for IPv4, DHCP for IPv6, IPv6 Router Advertisements). Similarly, local administrative procedures can allocate I and L values as required, e.g., I_H and L_H. This may be through manual configuration.

Additionally, if it is expected or desired that H might have incoming communication requests, e.g., it is a server, then the values I_H and L_H can be added to the relevant name services (e.g., DNS, NIS/YP), so that FQDN lookups for H resolve to the appropriate DNS resource records (e.g., NID, L32, L64, and LP [RFC6742]) for node H.

From a network operations perspective, this whole process also can be automated. As an example, consider that in Figure 3.1 the Site Border Router (SBR) is an IPv6-capable router and is connected via link1 to an ISP that supports IPv6. The SBR will have been allocated one (or more) IPv6 prefixes that it will multicast using IPv6 Routing Advertisements (RAs) into the site network, e.g., prefix L_1. L_1 is actually a local IPv6 prefix (/64), which is formed from an address assignment by the upstream ISP, according to [RFC3177] or [RFC6177]. Host H will see these RAs, for example, on its local interface with name eth0, will be able to use that prefix as a Locator value, and will cache that Locator value locally.

Also, node H can use the mechanism documented in either Section 2.5.1 of [RFC4291], in [RFC3972], [RFC4581], [RFC4982], or in [RFC4941] in order to create a default I value (say, I_H), just as an IPv6 host can. For DNS, the I_H and L_1 values may be pre-configured in DNS by an administrator who already has knowledge of these, or added to DNS by H using Secure DNS Dynamic Update [RFC3007] to add or update the correct NID and L64 records to DNS for the FQDN for H.

4.2. I-L Communication Cache

For the purposes of explaining the concept of operations, we talk of a local I-L Communication Cache (ILCC). This is an engineering convenience and does not form part of the ILNP architecture, but is used in our examples. More details on the ILCC can be found in [RFC6741]. The ILCC contains information that is required for the operation of ILNP. This will include, amongst other things, the current set of valid Identifier and Locator values in use by a node, the bindings between them, and the bindings between Locator values and interfaces.

4.3. Packet Forwarding

When the SBR needs to send a packet to H, it uses local address resolution mechanisms to discover the bindings between interface addresses and currently active I-LVs for H. For our example of Figure 3.1, IPv6 Neighbour Discovery (ND) can be used without modification, as the I-LV for ILNPv6 occupies the same bits as the IPv6 address in the IPv6 header. For packets from H to SBR, the same basic mechanism applies, as long as SBR supports IPv6 and even if it is not ILNPv6-capable, as IPv6 ND is used unmodified for ILNPv6.

For Figure 3.1, assuming:

- SBR advertises prefix L_1 locally, uses I value I_S, and has an Ethernet MAC address M_S on interface with local name sbr0
- H uses I value I_H, and has an Ethernet MAC address of M_H on the interface with local name eth0

then H will have in its ILCC:

```
[I_H, L_1]          --- (7a)
L_1, eth0          --- (7b)
```

After the IPv6 RA and ND mechanism has executed, the ILCC at H would contain, as well as expressions (7a) and (7b), the following entry for SBR:

```
[I_S, L_1], M_S    --- (8)
```

For ILNPv6, it does not matter that the SBR is not ILNPv6-capable, as the I-LV [I_S, L_1] is physically equivalent to the IPv6 address for the internal interface sbr0.

At SBR, which is not ILNP-capable, there would be the following entries in its local cache and configuration:

```
L_1:I_S            --- (9a)
L_1, sbr0          --- (9b)
```

Expression (9a) represents a valid IPv6 ND entry: in this case, the I_S value (which is 64 bits in ILNPv6) and the L_1 values are, effectively, concatenated and treated as if they were a single IPv6 address. Expression (9b) binds transmissions for L_1 to interface sbr0. (Again, sbr0 is a local, implementation-specific name, and such a binding is possible with standard tools today, for example, `ifconfig(8)`.)

4.4. Packet Routing

If we assume that host H is configured as in the previous section, it is now ready to send and receive ILNP packets.

Let us assume that, for Figure 4.1, it wishes to contact the node CN, which has FQDN `cn.example.com` and is ILNP-capable. A DNS query by H for `cn.example.com` will result in NID and L64 records for CN, with values `I_CN` and `L_CN`, respectively, being returned to H and stored in its ILCC:

```
[I_CN, L_CN] --- (10)
```

This will be considered active as long as the TTL values for the DNS records are valid. If the TTL for an I or L value is zero, then the value is still usable but becomes stale as soon as it has been used once. However, it is more likely that the TTL value will be greater than zero [BA11] [SBK01].

Once the CN's I value is known, the upper-layer protocol, e.g., the transport protocol, can set up suitable transport-layer session state:

```
<UDP: I_H, I_CN, P_H, P_CN> --- (11)
```

For routing of ILNP packets, the destination L value in an ILNPv6 packet header is semantically equivalent to a routing prefix. So, once a packet has been forwarded from a host to its first-hop router, only the destination L value needs to be used for getting the packet to the destination network. Once the packet has arrived at the router for the site network, local mechanisms and the packet-forwarding mechanism, as described above in Section 4.3, allow the packet to be delivered to the host.

For our example of Figure 4.1, H will send a UDP packet over ILNP as:

```
<UDP: I_H, I_CN, P_H, P_CN><ILNP: L_1, L_CN> --- (12a)
```

and CN will send UDP packets to H as:

```
<UDP: I_CN, I_H, P_CN, P_H><ILNP: L_CN, L_1> --- (12b)
```

The I value for H used in the transport-layer state (`I_H` in expression (12a)) selects the correct L value (`L_1` in this case) from the bindings in the ILCC (expression (7a)), and that, in turn, selects the correct interface from the ILCC (expression (7b)), as

described in Section 4.2. This gets the packet to the first hop router; beyond that, the ILNPv6 packet is treated as if it were an IPv6 packet.

5. Multihoming and Multi-Path Transport

For multihoming, there are three cases to consider:

- a) Host Multihoming (H-MH): a single host is, individually, connected to multiple upstream links, via separate routing paths, and those multiple paths are used by that host as it wishes. That is, use of multiple upstream links is managed by the single host itself. For example, the host might have multiple valid Locator values on a single interface, with each Locator value being associated with a different upstream link (provider).
- b) Multi-Path Transport (MTP): This is similar to using ILNP's support for host multihoming (i.e., H-MH), so we describe multi-path transport here. (Indeed, for ILNP, this can be considered a special case of H-MH.)
- c) Site Multihoming (S-MH): a site network is connected to multiple upstream links via separate routing paths, and hosts on the site are not necessarily aware of the multiple upstream paths. That is, the multiple upstream paths are managed, typically, through a site border router, or via the providers.

Essentially, for ILNP, multihoming is implemented by enabling:

- a) multiple Locator values to be used simultaneously by a node
- b) dynamic, simultaneous binding between one (or more) Identifier value(s) and multiple Locator values

With respect to the requirements for hosts [RFC1122], the multihoming function provided by ILNP is very flexible. It is not useful to discuss ILNP multihoming strictly within the confines of the exposition presented in Section 3.3.4 of [RFC1122], as that text is couched in terms of relationships between IP Addresses and interfaces, which can be dynamic in ILNP. The closest relationship between ILNP multihoming and [RFC1122] would be that certainly ILNP could support the notion of "Multiple Logical Networks", "Multiple Logical Hosts", and "Simple Multihoming".

5.1. Host Multihoming (H-MH)

At present, host multihoming is not common in the deployed Internet. When TCP or UDP are in use with an IP-based network-layer session, host multihoming cannot provide session resilience, because the transport protocol's pseudo-header checksum binds the transport-layer session to a single IP Address of the multihomed node, and hence to a single interface of that node. SCTP has a protocol-specific mechanism to support node multihoming; SCTP can support session resilience both at present and also without change in the proposed approach [RFC5061].

Host multihoming in ILNP is supported directly in each host by ILNP. The simplest explanation of H-MH for ILNP is that an ILNP-capable host can simultaneously use multiple Locator values, for example, by having a binding between an I value and two different L values, e.g., the ILCC may contain the I-LVs:

```
[I_1, L_1]          --- (14a)
[I_1, L_2]          --- (14b)
```

Additionally, a host may use several I values concurrently, e.g., the ILCC may contain the I-LVs:

```
[I_1, L_1]          --- (15a)
[I_1, L_2]          --- (15b)
[I_2, L_2]          --- (15c)
[I_3, L_1]          --- (15d)
```

Architecturally, ILNP considers these all to be cases of multihoming: the host is connected to more than one subnetwork, each subnetwork being named by a different Locator value.

In the cases above, the selection of which I-LV to use would be through local policy or through management mechanisms. Additionally, suitably modified transport-layer protocols, such as multi-path transport-layer protocol implementations, may make use of multiple I-LVs. Note that in such a case, the way in which multiple I-LVs are used would be under the control of the higher-layer protocol.

Recall, however, that L values also have preference -- LPI values -- and these LPI values can be used at the network layer, or by a transport-layer protocol implementation, in order make use of L values in a specific manner.

Note that, from a practical perspective, ILNP dynamically binds L values to interfaces on a node to indicate the SNPA for that L value, so the multihoming is very flexible: a node could have a single

interface and have multiple L values bound to that interface. For example, for expressions (14a) and (14b), if the end-system has a single interface with local name eth0, then the entries in the ILCC will be:

```
L_1, eth0          --- (16a)
L_2, eth0          --- (16b)
```

And, if we assume that for expressions (15a-c) the end-system has two interfaces, eth0 and eth1, then these ILCC entries are possible:

```
L_1, eth0          --- (17a)
L_2, eth1          --- (17b)
```

Let us consider the network in Figure 5.1.

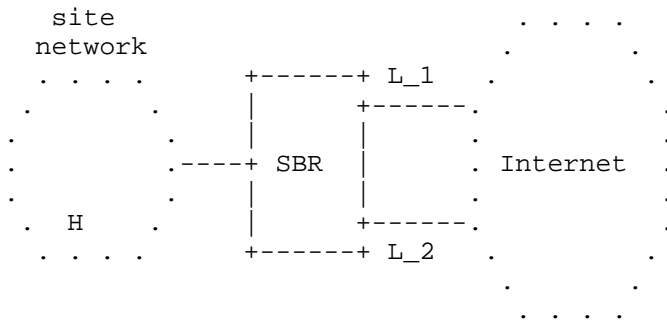

```
L_1 = global Locator value 1
L_2 = global Locator value 2
SBR = Site Border Router
```

Figure 5.1: A Simple Multihoming Scenario for ILNP

We assume that H has a single interface, eth0. SBR will advertise L_1 and L_2 internally to the site. Host H will configure these as both reachable via its single interface, eth0, by using ILCC entries as in expressions (16a) and (16b). When packets from H that are to egress the site network reach SBR, it can make appropriate decisions on which link to use based on the source Locator value (which has been inserted by H) or based on other local policy.

If, however, H has two interfaces, eth0 and eth1, then it can use ILCC entries as in expressions (17a) and (17b).

Note that the values L_1 and L_2 do not need to be PI-based Locator values, and can be taken from ISP-specific PA routing prefix allocations from the upstream ISPs providing the two links.

Of course, this example is illustrative: many other configurations are also possible, but the fundamental mechanism remains the same, as described above.

If any Locator values change, then H will discover this when it sees new Locator values in RAs from SBR, and sees that L values that were previously used are no longer advertised. When this happens, H will:

- a) maintain existing active network-layer sessions: based on its current ILCC entries and active sessions, send Locator Update (LU) messages to CNs to notify them of the change of L values. (LU messages are synonymous to Mobile IPv6 Binding Updates.)
- b) if required, update its relevant DNS entries with the new L value in the appropriate DNS records, to enable correct resolution for new incoming session requests.

From an engineering viewpoint, H also updates its ILCC data, removing the old L value(s) and replacing with new L value(s) as required.

Depending on the nature of the physical change in connectivity that the L value change represents, this may disrupt upper-level protocols, e.g., a fibre cut. Dealing with such physical-level disruption is beyond the scope of ILNP. However, ILNP supports graceful changes in L values, and this is explained below in Section 6 in the discussion on mobility support.

5.2. Support for Multi-Path Transport Protocols

ILNP supports deployment and use of multi-path transport protocols, such as the Multi-Path extensions to TCP (MP-TCP) being defined by the IETF TCPM Working Group. Specifically, ILNP will support the use of multiple paths as it allows a single I value to be bound to multiple L values -- see Section 5.1, specifically expressions (15a) and (15b).

Of course, there will be specific mechanisms for:

- congestion control
- signalling for connection/session management
- path discovery and path management
- engineering and implementation issues

These transport-layer mechanisms fall outside the scope of ILNP and would be defined in the multi-path transport protocol specifications.

As far as the ILNP architecture is concerned, the transport protocol connection is simply using multiple I-LVs, but with the same I value in each, and different L values, i.e., a multihomed host.

5.3. Site Multihoming (S-MH)

At present, site multihoming is common in the deployed Internet. This is primarily achieved by advertising the site's routing prefix(es) to more than one upstream Internet service provider at a given time. In turn, this requires de-aggregation of routing prefixes within the inter-domain routing system. This increases the entropy of the inter-domain routing system (e.g., RIB/FIB size increases beyond the minimal RIB/FIB size that would be required to reach all sites).

Site multihoming, in its simplest form in ILNP, is an extension of the H-MH scenario described in Section 5.1. If we consider Figure 5.1, and assume that there are many hosts in the site network, then each host can choose (a) whether or not to manage its own ILNP connectivity, and (b) whether or not to use multiple Locator values. This allows maximal control of connectivity for each host.

Of course, with ILNPv6, just as any IPv6 router is required to generate IPv6 Router Advertisement messages with the correct routing prefix information for the link the RA is advertised upon, the SBR is also required to generate RAs containing the correct Locator value(s) for the link that the RA is advertised upon. The correct values for these RA messages are typically configured by system administration, or might be passed down from the upstream provider.

To avoid a DNS Update burst when a site or (sub)network changes location, a DNS record optimisation is possible by using the new LP record for ILNP. This would change the number of DNS Updates required from Order(Number of nodes within the site/subnetwork that moved) to Order(1) [RFC6742].

5.3.1. A Common Multihoming Scenario - Multiple SBRs

The scenario of Figure 5.1 is an example to illustrate the architectural operation of multihoming for ILNP. For site multihoming, a scenario such as the one depicted in Figure 5.2 is also common. Here, there are two SBRs, each with its own global connectivity.

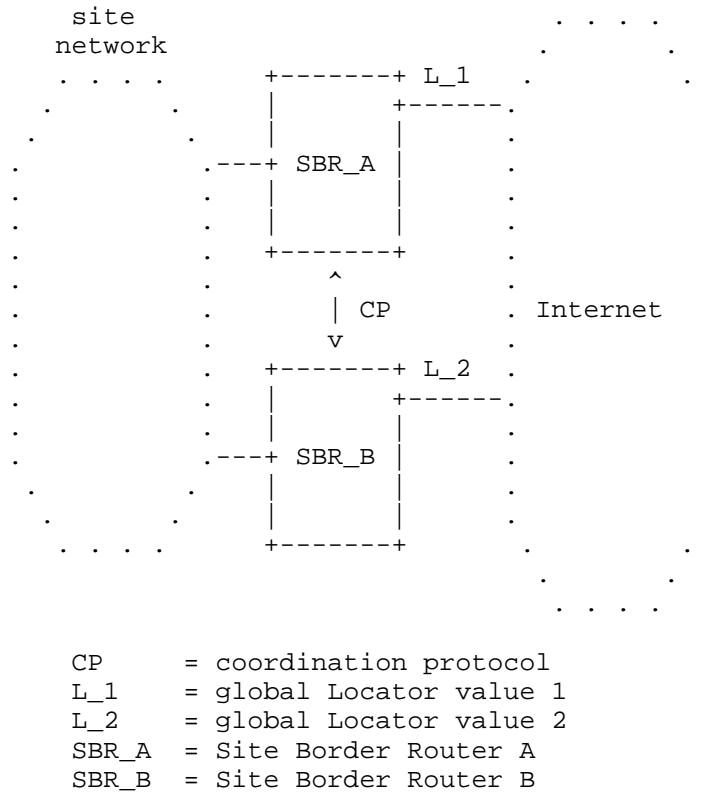

Figure 5.2: A Dual-Router Multihoming Scenario for ILNP

The use of two physical routers provides an extra level of resilience compared to the scenario of Figure 5.1. The coordination protocol (CP) between the two routers keeps their actions in synchronisation according to whatever management policy is in place for the site network. Such capabilities are available today in products. Note that, logically, there is little difference between Figures 5.1 and 5.2, but with two distinct routers in Figure 5.2, the interaction using CP is required. Of course, it is also possible to have multiple interfaces in each router and more than two routers.

5.4. Multihoming Requirements for Site Border Routers

For multihoming, the SBR does NOT need to be ILNP-capable for host multihoming or site multihoming. This is true provided the multihoming is left to individual hosts as described above. In this deployment approach, the SBR need only issue Routing Advertisements

(RAs) that are correct with respect to its upstream connectivity; that is, the SBR properly advertises routing prefixes (Locator values) to the ILNP hosts.

In such a scenario, when hosts in the site network see new Locator values, and see that a previous Locator value is no longer being advertised, those hosts can update their ILCCs, send Locator Updates to CNs, and change connectivity as required.

6. Mobility

ILNP supports mobility directly, rather than relying upon special-purpose mobility extensions as is the case with both IPv4 [RFC2002] (which was obsoleted by [RFC5944]) and IPv6 [RFC6275].

There are two different mobility cases to consider:

- a) Host Mobility: individual hosts may be mobile, moving across administrative boundaries or topological boundaries within an IP-based network, or across the Internet. Such hosts would need to independently manage their own mobility.
- b) Network (Site) Mobility: a whole site, i.e., one or more IP subnetworks may be mobile, moving across administrative boundaries or topological boundaries within an IP-based network, or across the Internet. The site as a whole needs to maintain consistency in connectivity.

Essentially, for ILNP, mobility is implemented by enabling:

- a) Locator values to be changed dynamically by a node, including for active network-layer sessions.
- b) use of Locator Updates to allow active network-layer sessions to be maintained.
- c) for those hosts that expect incoming network-layer or transport-layer session requests (e.g., servers), updates to the relevant DNS entries for those hosts.

It is possible that a device is both a mobile host and part of a mobile network, e.g., a smartphone in a mobile site network. This is supported in ILNP as the mechanism for mobile hosts and mobile networks are very similar and work in harmony.

For mobility, there are two general features that must be supported:

- a) Handover (or Hand-off): when a host changes its connectivity (e.g., it has a new SNPA as it moves to a new ILNP subnetwork), any active network-layer sessions for that host must be maintained with minimal disruption (i.e., transparently) to the upper-layer protocols.
- b) Rendezvous: when a host that expects incoming network-layer or transport-layer session requests has new connectivity (e.g., it has a new SNPA as it moves to a new ILNP subnetwork), it needs to update its relevant DNS entries so that name resolution will provide the correct I and L values to remote nodes.

6.1. Mobility / Multihoming Duality in ILNP

Mobility and multihoming present the same set of issues for ILNP. Indeed, mobility and multihoming form a duality: the set of Locators associated with a node or site changes. The reason for the change might be different for the case of mobility and multihoming, but the effects on the network-layer session state and on correspondents is identical.

With ILNP, mobility and multihoming are supported using a common set of mechanisms. In both cases, different Locator values are used to identify different IP subnetworks. Also, ILNP nodes that expect incoming network-layer or transport-layer session requests are assumed to have a Fully Qualified Domain Name (FQDN) stored in the Domain Name System (DNS), as is already done within the deployed Internet. ILNP mobility normally relies upon the Secure Dynamic DNS Update standard for mobile nodes to update their location information in the DNS. This approach of using DNS for rendezvous with mobile systems was proposed earlier by others [PHG02].

Host Mobility considers individual hosts that are individually mobile -- for example, a mobile telephone carried by a person walking in a city. Network (Site) Mobility considers a group of hosts within a local topology that move jointly and periodically change their uplinks to the rest of the Internet -- for example, a ship that has wired connections internally but one or more wireless uplinks to the rest of the Internet.

For ILNP, Host Mobility is analogous to host multihoming (H-MH) and Network Mobility is analogous to site multihoming (S-MH). So, mobility and multihoming capabilities can be used together, without conflict.

6.2. Host Mobility

With Host Mobility, each individual end-system manages its own connectivity through the use of Locator values. (This is very similar to the situation described for H-MH in Section 5.1.)

Let us consider the network in Figure 6.1.

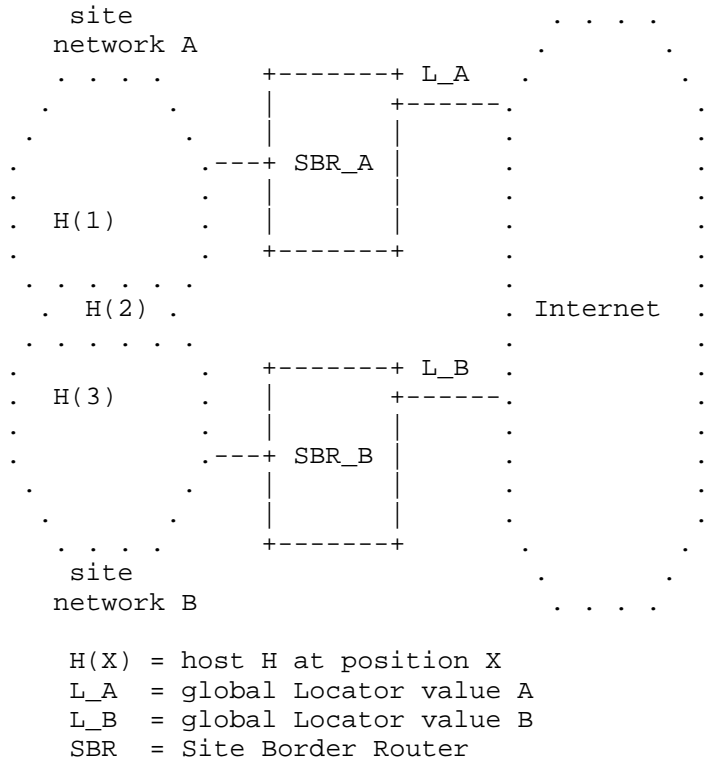

Figure 6.1: A Simple Mobile Host Scenario for ILNP

A host H is at position (1), hence H(1) in a site network A. This site network might be, for example, a single radio cell under administrative domain A. We assume that the host will move into site network B, which might be a single radio cell under administrative domain B. We also assume that the site networks have a region of overlap so that connectivity can be maintained; else, of course, the host will lose connectivity. Also, let us assume that the host already has ILNP connectivity in site network A.

If site network A has connectivity via Locator value `L_A`, and H uses Identifier value `I_H` with a single interface `ra0`, then the host's ILCC will contain:

```
[I_H, L_A]          --- (18a)
L_A, ra0           --- (18b)
```

Note the equivalence of expressions (18a) and (18b), respectively, with the expressions (15a) and (16a) for host multihoming.

The host now moves into the overlap region of site networks A and B, and has position (2), hence `H(2)` as indicated in Figure 6.1. As this region is now in site network B, as well as site network A, H should see RAs from `SBR_B` for `L_B`, as well as the RAs for `L_A` from `SBR_A`. The host can now start to use `L_B` for its connectivity. The host H must now:

- a) maintain existing active upper-layer sessions: based on its current ILCC entries and active sessions, send Locator Update (LU) messages to CNS to notify them of the change of L values. (LU messages are synonymous to Mobile IPv6 Binding Updates.)
- b) if required, update its relevant DNS entries with the new L value in the appropriate DNS records, to enable correct resolution for new incoming network-layer or transport-layer session requests.

However, it can opt to do this one of two ways:

- 1) immediate handover: the host sends Locator Update (LU) messages to CNS, immediately stops using `L_A`, and switches to using `L_B` only. In this case, its ILCC entries change to:

```
[I_H, L_B]          --- (19a)
L_B, ra0           --- (19b)
```

There might be packets in flight to H that use `L_A`, and H MAY choose to ignore these on reception.

- 2) soft handover: the host sends Locator Update (LU) messages to CNS, but it uses both `L_A` and `L_B` until (i) it no longer receives incoming packets with destination Locator values set to `L_A` within a given time period and (ii) it no longer sees RAs for `L_A` (i.e., it has left the overlap region and so has left site network A). In this case, its ILCC entries change to:

[I_H, L_A]	---	(20a)
L_A, ra0	---	(20b)
[I_H, L_B]	---	(20c)
L_B, ra0	---	(20d)

ILNP does not mandate the use of one handover option over another. Indeed, a host may implement both and decide, through local policy or other mechanisms (e.g., under the control of a particular transport protocol implementation), to use one or other for a specific transport-layer session, as required.

Note that if using soft handover, when in the overlap region, the host is multihomed. Also, soft handover is likely to provide a less disruptive handover (e.g., lower packet loss) compared to immediate handover, all other things being equal.

There is a case where both the host and its correspondent node are mobile. In the unlikely event of simultaneous motion that changes both nodes' Locators within a very small time period, there is the possibility that communication may be lost. If the communication between the nodes was direct (i.e., one node initiated communication with another, through a DNS lookup), a node can use the DNS to discover the new Locator value(s) for the other node. If the communication was through some sort of middlebox providing a relay service, then communication is more likely to be disrupted only if the middlebox is also mobile.

It is also possible that high packet loss results in Locator Updates being lost, which could disrupt handover. However, this is an engineering issue and does not impact the basic concept of operation; additional discussion on this issue is provided in [RFC6741].

Of course, for any handover, the new end-to-end path through SBR_B might have very different end-to-end path characteristics (e.g., different end-to-end delay, packet loss, throughput). Also, the physical connectivity on interface ra0 as well as through SBR_B's uplink may be different. Such impacts on end-to-end packet transfer are outside the scope of ILNP.

6.3. Network Mobility

For network mobility, a whole site may be mobile, e.g., the SBRs of Figure 6.1 have a radio uplink on a moving vehicle. Within the site, individual hosts may or may not be mobile.

In the simplest case, ILNP deals with mobile networks in the same way as for site multihoming: the management of mobility is delegated to each host in the site, so it needs to be ILNP-capable. Each host,

effectively, behaves as if it were a mobile host, even though it may not actually be mobile. Indeed, in this way, the mechanism is very similar to that for site multihoming. Let us consider the mobile network in Figure 6.2.

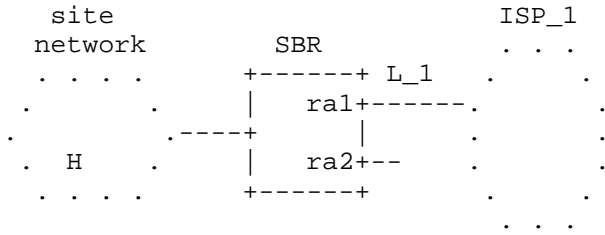

Figure 6.2a: ILNP Mobile Network before Handover

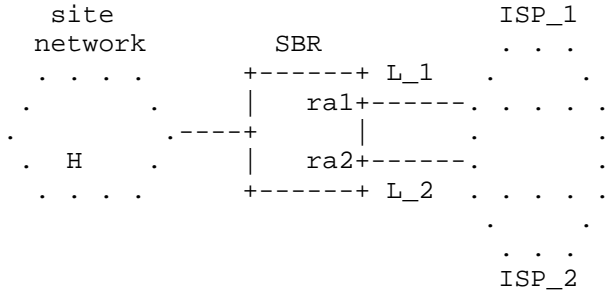

Figure 6.2b: ILNP Mobile Network during Handover

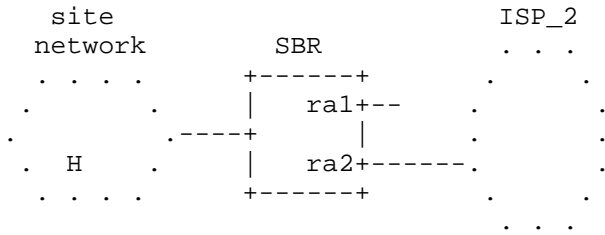

Figure 6.2c: ILNP Mobile Network after Handover

H = host
L_1 = global Locator value 1
L_2 = global Locator value 2
SBR = Site Border Router

Figure 6.2: A Simple Mobile Network Scenario for ILNP

In Figure 6.2, we assume that the site network is mobile, and the SBR has two radio interfaces `ra1` and `ra2`. However, this particular figure is chosen for simplicity and clarity for our scenario, and other configurations are possible, e.g., a single radio interface which uses separate radio channels (separate carriers, coding channels, etc.). In the figure, `ISP_1` and `ISP_2` are separate, radio-based service providers, accessible via `ra1` and `ra2`.

In Figure 6.2a, the SBR has connectivity via `ISP_1` using Locator value `L_1`. The host `H`, with interface `ra0` and Identifier `I_H`, has an established connectivity via the SBR and so has ILCC entries as shown in (21):

```
[I_H, L_1]          --- (21a)
L_1, ra0           --- (21b)
```

Note the equivalence to expressions (18a) and (18b). As the whole network moves, the SBR detects a new radio provider, `ISP_2`, and connects to it using `ra2`, as shown in Figure 6.2b, with the service areas of `ISP_1` and `ISP_2` overlapping. `ISP_2` provides Locator `L_2`, which the SBR advertises into the site network along with `L_1`. As with the mobile host scenario above, individual hosts may decide to perform immediate handover or soft handover. So, the ILCC state for `H` will be as for expressions (19a) and (19b) and (20a)-(20d), but with `L_1` in place of `L_A`, and `L_2` in place of `L_B`. Finally, as in Figure 6.2c, the site network moves and is no longer served by `ISP_1`, and handover is complete. Note that during the handover the site is multihomed, as in Figure 6.2b.

6.4. Mobility Requirements for Site Border Routers

As for multihoming, the SBR does NOT need to be ILNP-capable: it simply needs to advertise the available routing prefixes into the site network. The mobility capability is handled completely by the hosts.

6.5. Mobility with Multiple SBRs

Just as Section 5.3.1 describes the use of multiple routers for multihoming, so it is possible to have multiple routers for mobility for ILNP, for both mobile hosts and mobile networks.

7. IP Security for ILNP

IP Security for ILNP [RFC6741] becomes simpler, in principle, than IPsec as it is today, based on the use of IP Addresses as Identifiers.

An operational issue in the deployed IP Internet is that the IPsec protocols, AH and ESP, have Security Associations (IPsec SAs) that include the IP Addresses of the secure IPsec session endpoints. This was understood to be a problem when AH and ESP were originally defined in [RFC1825], [RFC1826], and [RFC1827] (which were obsoleted by [RFC4301], [RFC4302], and [RFC4303]). However, the limited set of namespaces in the Internet Architecture did not provide any better choices at that time. ILNP provides more namespaces, thus now enabling better IPsec architecture and engineering.

7.1. Adapting IP Security for ILNP

In essence, ILNP provides a very simple architectural change to IPsec: in place of IP Addresses as used today for IPsec SAs, ILNP uses Node Identifier values instead. Recall that Identifier values are immutable once in use, so they can be used to maintain end-to-end state for any protocol that requires it. Note from the discussion above that the Identifier values for a host remain unchanged when multihoming and mobility are in use, so IPsec using ILNP can work in harmony with multihoming and mobility [ABH08b] [ABH09a].

To resolve the issue of IPsec interoperability through a Network Address Translator (NAT) deployment [RFC1631] [RFC3022], UDP encapsulation of IPsec [RFC3948] is commonly used as of the date this document was published. This special-case handling for IPsec traffic traversing a NAT is not needed with ILNP IPsec.

Further, it would obviate the need for specialised IPsec NAT traversal mechanisms, thus simplifying IPsec implementations while enhancing deployability and interoperability [RFC3948].

This architectural change does not reduce the security provided by the IPsec protocols. In fact, had the Node Identifier namespace existed back in the early 1990s, IPsec would always have bound to that location-independent Node Identifier and would not have bound to IP Addresses.

7.2. Operational Use of IP Security with ILNP

Operationally, this change in SA bindings to use Identifiers rather than IP Addresses causes problems for the use of the IPsec protocols through IP Network Address Translation (NAT) devices, with mobile nodes (because the mobile node's IP Address changes at each network-layer handoff), and with multihomed nodes (because the network-layer IPsec session is bound to a particular interface of the multihomed node, rather than being bound to the node itself) [RFC3027] [RFC3715].

8. Backwards Compatibility and Incremental Deployment

ILNPv6 is fully backwards compatible with existing IPv6. No router software or silicon changes are necessary to support the proposed enhancements. An IPv6 router would be unaware whether the packet being forwarded were classic IPv6 or the proposed enhancement in ILNPv6. IPv6 Neighbour Discovery will work unchanged for ILNPv6. ILNPv6 multicasting is the same as IETF standards-track IPv6 multicasting.

ILNPv4 is backwards compatible with existing IPv4. As the IPv4 address fields are used as 32-bit Locators, using only the address prefix bits of the 32-bit space, IPv4 routers also would not require changes. An IPv4 router would be unaware whether the packet being forwarded were classic IPv4 or the proposed enhancement in ILNPv4 [RFC6746]. ARP [RFC826] requires enhancements to support ILNPv4 [RFC6747] [RFC6741]. ILNPv4 multicasting is the same as IETF standards-track IPv4 multicasting.

If a node supports ILNP and intends to receive incoming network-layer or transport-layer sessions, the node's Fully Qualified Domain Name (FQDN) normally will have one or more NID records and one or more Locator (i.e., L32, L64, and/or LP) records associated with the node within the DNS [RFC6741] [RFC6742].

When an IP host ("initiator") initiates a new network-layer session with a correspondent ("responder"), it normally will perform a DNS lookup to determine the address(es) of the responder. An ILNP host normally will look for Node Identifier ("NID") and Locator (i.e., L32, L64, and LP) records in any received DNS replies. DNS servers that support NID and Locator (i.e., L32, L64, and LP) records SHOULD include them (when they exist) as additional data in all DNS replies to queries for DNS AAAA records [RFC6742].

If the initiator supports ILNP, and from DNS information learns that the responder also supports ILNP, then the initiator will generate an unpredictable ILNP Nonce value, cache that value locally as part of the network-layer ILNP session, and will include the ILNP Nonce value in its initial packet(s) to the responder [RFC6741] [RFC6744] [RFC6746].

If the initiator node does not find any ILNP-specific DNS resource records for the responder node, then the initiator uses classic IP for the new network-layer session with the responder, rather than trying to use ILNP for that network-layer session. Of course, multiple transport-layer sessions can concurrently share a single network-layer (e.g., IP or ILNP) session.

If the responder node for a new network-layer session does not support ILNP and the responder node receives initial packet(s) containing the ILNP Nonce, then the responder will drop the packet and send an ICMP error message back to the initiator. If the responder node for a new network-layer session supports ILNP and receives initial packet(s) containing the ILNP Nonce, the responder learns that ILNP is in use for that network-layer session (i.e., by the presence of that ILNP Nonce).

If the initiator node using ILNP does not receive a response from the responder in a timely manner (e.g., within TCP timeout for a TCP session) and also does not receive an ICMP Unreachable error message for that packet, OR if the initiator receives an ICMP Parameter Problem error message for that packet, then the initiator concludes that the responder does not support ILNP. In this case, the initiator node SHOULD try again to create the new network-layer session, but this time using IP (and therefore omitting the ILNP Nonce).

Finally, since an ILNP node also is a fully capable IP node, the upgraded node can use any standardised IP mechanisms for communicating with a legacy IP-only node. So, ILNP will not be worse than existing IP, but when ILNP is used, the enhanced capabilities described in these ILNP documents will be available.

9. Security Considerations

This proposal outlines a proposed evolution for the Internet Architecture to provide improved capabilities. This section discusses security considerations for this proposal.

Note that ILNP provides security equivalent to IP for similar threats when similar mitigations (e.g., IPsec or not) are in use. In some cases, but not all, ILNP exceeds that objective and has lower security risk than IP. Additional engineering details for several of these topics can be found in [RFC6741].

9.1. Authentication of Locator Updates

All Locator Update messages are authenticated. ILNP requires use of an ILNP session nonce [RFC6744] [RFC6746] to prevent off-path attacks, and also allows use of IPsec cryptography to provide stronger protection where required.

Ordinary network-layer sessions based on IP are vulnerable to on-path attacks unless IPsec is used. So the Nonce Destination Option only seeks to provide protection against off-path attacks on an ILNP-based network-layer session -- equivalent to ordinary IP-based network-layer sessions that are not using IPsec.

It is common to have non-symmetric paths between two nodes on the Internet. To reduce the number of on-path nodes that know the Nonce value for a given session when ILNP is in use, a nonce value is unidirectional, not bidirectional. For example, for a network-layer ILNP-based session between nodes A and B, one nonce value is used from A to B and a different nonce value is used from B to A.

ILNP sessions operating in higher risk environments SHOULD also use the cryptographic authentication provided by IPsec *in addition* to concurrent use of the ILNP Nonce.

It is important to note that, at present, a network-layer IP-based session is entirely vulnerable to on-path attacks unless IPsec is in use for that particular IP session, so the security properties of the new proposal are never worse than for existing IP.

9.2. Forged Identifier Attacks

In the deployed Internet, active attacks using packets with a forged Source IP Address have been publicly known at least since early 1995 [CA-1995-01]. While these exist in the deployed Internet, they have not been widespread. This is equivalent to the issue of a forged Identifier value and demonstrates that this is not a new threat created by ILNP.

One mitigation for these attacks has been to deploy Source IP Address filtering [RFC2827] [RFC3704]. Jun Bi at Tsinghua University cites Arbor Networks as reporting that this mechanism has less than 50% deployment and cites an MIT analysis indicating that at least 25% of the deployed Internet permits forged Source IP Addresses.

In [RFC6741], there is a discussion of an accidental use of a duplicate Identifier on the Internet. However, this sub-section instead focuses on methods for mitigating attacks based on packets containing deliberately forged Source Identifier values.

Firstly, the recommendations of [RFC2827] and [RFC3704] remain. So, any packets that have a forged Locator value can be easily filtered using existing widely available mechanisms.

Secondly, the receiving node does not blindly accept any packet with the proper Source Identifier and proper Destination Identifier as an authentic packet. Instead, each ILNP node maintains an ILNP Communication Cache (ILCC) for each of its correspondents, as described in [RFC6741]. Information in the cache is used in validating received messages and preventing off-path attackers from succeeding. This process is discussed more in [RFC6741].

Thirdly, any node can distinguish different nodes using the same Identifier value by other properties of their ILNP sessions. For example, IPv6 Neighbor Discovery prevents more than one node from using the same source I-LV at the same time on the same link [RFC4861]. So, cases of different nodes using the same Identifier value will involve nodes that have different sets of valid Locator values. A node thus can demultiplex based on the combination of Source Locator and Source Identifier if necessary. If IPsec is in use, the combination of the Source Identifier and the Security Parameter Index (SPI) value would be sufficient to demux two different ILNP sessions.

Fourthly, deployments in high-threat environments also SHOULD use IPsec to authenticate control traffic and data traffic. Because IPsec for ILNP binds only to the Identifier values, and never to the Locator values, a mobile or multihomed node can use IPsec even when its Locator value(s) have just changed.

Lastly, note well that ordinary IPv4, ordinary IPv6, Mobile IPv4, and also Mobile IPv6 already are vulnerable to forged Identifier and/or forged IP Address attacks. An attacker on the same link as the intended victim simply forges the victims MAC address and the victim's IP Address. With IPv6, when Secure Neighbour Discovery (SEND) and Cryptographically Generated Addresses (CGAs) are in use, the victim node can defend its use of its IPv6 address using SEND. With ILNP, when SEND and CGAs are in use, the victim node also can defend its use of its IPv6 address using SEND. There are no standard mechanisms to authenticate ARP messages, so IPv4 is especially vulnerable to this sort of attack. These attacks also work against Mobile IPv4 and Mobile IPv6. In fact, when either form of Mobile IP is in use, there are additional risks, because the attacks work not only when the attacker has access to the victim's current IP subnetwork but also when the attacker has access to the victim's home IP subnetwork. Thus, the risks of using ILNP are not greater than exist today with IP or Mobile IP.

9.3. IP Security Enhancements

The IPsec standards are enhanced here by binding IPsec Security Associations (SAs) to the Node Identifiers of the endpoints, rather than binding IPsec SAs to the IP Addresses of the endpoints as at present. This change enhances the deployability and interoperability of the IPsec standards, but does not decrease the security provided by those protocols. See Section 7 for a more detailed explanation.

9.4. DNS Security

The DNS enhancements proposed here are entirely compatible with, and can be protected using, the existing IETF standards for DNS Security [RFC4033]. The Secure DNS Dynamic Update mechanism used here is also used unchanged [RFC3007]. So, ILNP does not change the security properties of the DNS or of DNS servers.

9.5. Firewall Considerations

In the proposed new scheme, stateful firewalls are able to authenticate ILNP-specific control messages arriving on the external interface. This enables more thoughtful handling of ICMP messages by firewalls than is commonly the case at present. As the firewall is along the path between the communicating nodes, the firewall can snoop on the ILNP Nonce being carried in the initial packets of an ILNP session. The firewall can verify the correct ILNP Nonce is present on incoming control packets, dropping any control packets that lack the correct nonce value.

By always including the ILNP Nonce in ILNP-specific control messages, even when IPsec is also in use, the firewall can filter out off-path attacks against those ILNP messages without needing to perform computationally expensive IPsec processing. In any event, a forged packet from an on-path attacker will still be detected when the IPsec input processing occurs in the receiving node; this will cause that forged packet to be dropped rather than acted upon.

9.6. Neighbour Discovery Authentication

Nothing in this proposal prevents sites from using the Secure Neighbour Discovery (SEND) proposal for authenticating IPv6 Neighbour Discovery with ILNPv6 [RFC3971].

9.7. Site Topology Obfuscation

A site that wishes to obscure its internal topology information MAY do so by deploying site border routers that rewrite the Locator values for the site as packets enter or leave the site. This operational scenario was presented in [ABH09a] and is discussed in more detail in [RFC6748].

For example, a site might choose to use a ULA prefix internally for this reason [RFC4193] [ID-ULA]. In this case, the site border routers would rewrite the Source Locator of ILNP packets leaving the site to a global-scope Locator associated with the site. Also, those site border routers would rewrite the Destination Locator of packets entering the site from the global-scope Locator to an appropriate interior ULA Locator for the destination node [ABH08b] [ABH09a] [RFC6748].

10. Privacy Considerations

ILNP has support for both:

- Location Privacy: to hide a node's topological location by obfuscating the ILNP Locator information. (See also Section 7 of [RFC6748].)
- Identity Privacy: to hide a node's identity by allowing the use of Node Identifier values that are not tied to the node in some permanent or semi-permanent manner. (See also Section 11 of [RFC6741].)

A more detailed exposition of the possibilities is given in [BAK11].

10.1. Location Privacy

Some users have concerns about the issue of "location privacy", whereby the user's location might be determined by others. The term "location privacy" does not have a crisp definition within the Internet community at present. Some mean the location of a node relative to the Internet's routing topology, while others mean the geographic coordinates of the node (i.e., latitude X, longitude Y). The concern seems to focus on Internet-enabled devices, most commonly handheld devices such as a smartphone, that might have 1:1 mappings with individual users.

There is a fundamental trade-off here. Quality of a node's Internet connectivity tends to be inversely proportional to the "location privacy" of that node. For example, if a node were to use a router with NAT as a privacy proxy, routing all traffic to and from the

Internet via that proxy, then (a) latency will increase as the distance increases between the node seeking privacy and its proxy, and (b) communications with the node seeking privacy will be more vulnerable to communication faults -- both due to the proxy itself (which might fail) and due to the longer path (which has more points of potential failure than a more direct path would have).

Any Internet node that wishes for other Internet nodes to be able to initiate transport-layer or network-layer sessions with it needs to include associated address (e.g., A, AAAA) or Locator (e.g., L32, L64, LP) records in the publicly accessible Domain Name System (DNS). Information placed in the DNS is publicly accessible. Since the goal of DNS is to distribute information to other Internet nodes, it does not provide mechanisms for selective privacy. Of course, a node that does not wish to be contacted need not be present in the DNS.

In some cases, various parties have attempted to create mappings between IP Address blocks and geographic locations. The quality of such mappings appears to vary [GUF07]. Many such mapping efforts are driven themselves by efforts to comply with legal requirements in various legal jurisdictions. For example, some content providers reportedly have licenses authorising distribution of content in one set of locations, but not in a different set of locations.

ILNP does not compromise user location privacy any more than base IPv6. In fact, by its nature ILNP provides additional choices to the user to protect their location privacy.

10.2. Identity Privacy

Both ILNP and IPv6 permit use of identifier values generated using the IPv6 Privacy Address extension [RFC4941]. ILNP and IPv6 also support a node having multiple unicast addresses/locators at the same time, which facilitates changing the node's addresses/locators over time. IPv4 does not have any non-topological identifiers, and many IPv4 nodes only support one IPv4 unicast address per interface, so IPv4 is not directly comparable with IPv6 or ILNP.

In normal operation with IPv4, IPv6, or ILNP, a mobile node might intend to be accessible for new connection attempts from the global Internet and also might wish to have both optimal routing and maximal Internet availability, both for sent and received packets. In that case, the node will want to have its addressing or location information kept in the DNS and made available to others.

In some cases, a mobile node might only desire to initiate network-layer or transport-layer sessions with other Internet nodes, and thus not desire to be a responder, in which case that node need not be

present in the DNS. Some potential correspondent nodes might, as a matter of local security policy, decline to communicate with nodes that do not have suitable DNS records present in the DNS. For example, some deployed IPv4-capable mail relays refuse to communicate with an initiating node that lacks an appropriate PTR record in the DNS.

In some cases (for example, intermittent electronic mail access or browsing specific web pages), support for long-lived network sessions (i.e., where network-layer session lifetime is longer than the time the node remains on the same subnetwork) is not required. In those cases, support for node mobility (i.e., network-layer session continuity even when the SNPA changes) is not required and need not be used.

If an ILNP node that is mobile chooses not to use DNS for rendezvous, yet desires to permit any node on the global Internet to initiate communications with that node, then that node may fall back to using Mobile IPv4 or Mobile IPv6 instead.

Many residential broadband Internet users are subject to involuntary renumbering, usually when their ISP's DHCP server(s) deny a DHCP RENEW request and instead issue different IP addressing information to the residential user's device(s). In many cases, such users want their home server(s) or client(s) to be externally reachable. Such users today often use Secure DNS Dynamic Update to update their addressing or location information in the DNS entries, for the devices they wish to make reachable from the global Internet [RFC2136] [RFC3007] [LA2006]. This option exists for those users, whether they use IPv4, IPv6, or ILNP. Users also have the option not to use such mechanisms.

11. References

11.1. Normative References

- [RFC768] Postel, J., "User Datagram Protocol", STD 6, RFC 768, August 1980.
- [RFC791] Postel, J., "Internet Protocol", STD 5, RFC 791, September 1981.
- [RFC793] Postel, J., "Transmission Control Protocol", STD 7, RFC 793, September 1981.

- [RFC826] Plummer, D., "Ethernet Address Resolution Protocol: Or Converting Network Protocol Addresses to 48.bit Ethernet Address for Transmission on Ethernet Hardware", STD 37, RFC 826, November 1982.
- [RFC2119] Bradner, S., "Key words for use in RFCs to Indicate Requirement Levels", BCP 14, RFC 2119, March 1997.
- [RFC2460] Deering, S. and R. Hinden, "Internet Protocol, Version 6 (IPv6) Specification", RFC 2460, December 1998.
- [RFC3007] Wellington, B., "Secure Domain Name System (DNS) Dynamic Update", RFC 3007, November 2000.
- [RFC4033] Arends, R., Austein, R., Larson, M., Massey, D., and S. Rose, "DNS Security Introduction and Requirements", RFC 4033, March 2005.
- [RFC4861] Narten, T., Nordmark, E., Simpson, W., and H. Soliman, "Neighbor Discovery for IP version 6 (IPv6)", RFC 4861, September 2007.
- [RFC6724] Thaler, D., Ed., Draves, R., Matsumoto, A., and T. Chown, "Default Address Selection for Internet Protocol Version 6 (IPv6)", RFC 6724, September 2012.
- [RFC6741] Atkinson, R. and S. Bhatti, "Identifier-Locator Network Protocol (ILNP) Engineering and Implementation Considerations", RFC 6741, November 2012.
- [RFC6742] Atkinson, R., Bhatti, S., and S. Rose, "DNS Resource Records for the Identifier-Locator Network Protocol (ILNP)", RFC 6742, November 2012.
- [RFC6743] Atkinson, R. and S. Bhatti, "ICMPv6 Locator Update Message", RFC 6743, November 2012.
- [RFC6744] Atkinson, R. and S. Bhatti, "IPv6 Nonce Destination Option for the Identifier-Locator Network Protocol for IPv6 (ILNPv6)", RFC 6744, November 2012.
- [RFC6745] Atkinson, R. and S. Bhatti, "ICMP Locator Update Message for the Identifier-Locator Network Protocol for IPv4 (ILNPv4)", RFC 6745, November 2012.
- [RFC6746] Atkinson, R. and S. Bhatti, "IPv4 Options for the Identifier-Locator Network Protocol (ILNP)", RFC 6746, November 2012.

- [RFC6747] Atkinson, R. and S. Bhatti, "Address Resolution Protocol (ARP) Extension for the Identifier-Locator Network Protocol for IPv4 (ILNPv4)", RFC 6747, November 2012.

11.2. Informative References

- [8+8] O'Dell, M., "8+8 - An Alternate Addressing Architecture for IPv6", Work in Progress, October 1996.
- [ABH07a] Atkinson, R., Bhatti, S., and S. Hailes, "Mobility as an Integrated Service Through the Use of Naming", Proceedings of ACM MobiArch 2007, August 2007, Kyoto, Japan.
- [ABH07b] Atkinson, R., Bhatti, S., and S. Hailes, "A Proposal for Unifying Mobility with Multi-Homing, NAT, & Security", Proceedings of ACM MobiWAC 2007, Chania, Crete. ACM, October 2007.
- [ABH08a] Atkinson, R., Bhatti, S., and S. Hailes, "Mobility Through Naming: Impact on DNS", Proceedings of ACM MobiArch 2008, August 2008, ACM, Seattle, WA, USA.
- [ABH08b] Atkinson, R., Bhatti, S., and S. Hailes, "Harmonised Resilience, Security, and Mobility Capability for IP", Proceedings of IEEE Military Communications (MILCOM) Conference, San Diego, CA, USA, November 2008.
- [ABH09a] Atkinson, R., Bhatti, S., and S. Hailes, "Site-Controlled Secure Multi-Homing and Traffic Engineering For IP", Proceedings of IEEE Military Communications (MILCOM) Conference, Boston, MA, USA, October 2009.
- [ABH09b] Atkinson, R., Bhatti, S., and S. Hailes, "ILNP: Mobility, Multi-Homing, Localised Addressing and Security Through Naming", Telecommunications Systems, Volume 42, Number 3-4, pp. 273-291, Springer-Verlag, December 2009, ISSN 1018-4864.
- [ABH10] Atkinson, R., Bhatti, S., S. Hailes, "Evolving the Internet Architecture Through Naming", IEEE Journal on Selected Areas in Communication (JSAC), vol. 28, no. 8, pp. 1319-1325, IEEE, Piscataway, NJ, USA, Oct 2010.
- [BA11] Bhatti, S. and R. Atkinson, "Reducing DNS Caching", Proceedings of IEEE Global Internet Symposium (GI2011), Shanghai, P.R. China, 15 April 2011.

- [BA12] Bhatti, S. and R. Atkinson, "Secure and Agile Wide-area Virtual Machine Mobility", Proceedings of IEEE Military Communications Conference (MILCOM), Orlando, FL, USA, Oct 2012.
- [BAK11] Bhatti, S., Atkinson, R., and J. Klemets, "Integrating Challenged Networks", Proceedings of IEEE Military Communications Conference (MILCOM), Baltimore, MD, USA, November 2011.
- [CA-1995-01] US CERT, "IP Spoofing Attacks and Hijacked Terminal Connections", CERT Advisory 1995-01, Issued 23 Jan 1995, Revised 23 Sep 1997.
- [DIA] Defense Intelligence Agency, "Compartmented Mode Workstation Specification", Technical Report DDS-2600-6243-87, US Defense Intelligence Agency, Bolling AFB, DC, USA.
- [DoD85] US National Computer Security Center, "Department of Defense Trusted Computer System Evaluation Criteria", DoD 5200.28-STD, US Department of Defense, Ft. Meade, MD, USA, December 1985.
- [DoD87] US National Computer Security Center, "Trusted Network Interpretation of the Trusted Computer System Evaluation Criteria", NCSC-TG-005, Version 1, US Department of Defense, Ft. Meade, MD, USA, 31 July 1987.
- [GSE] O'Dell, M., "GSE - An Alternate Addressing Architecture for IPv6", Work in Progress, February 1997.
- [GUF07] Gueye, B., Uhlig, S., and S. Fdida, "Investigating the Imprecision of IP Block-Based Geolocation", Lecture Notes in Computer Science, Volume 4427, pp. 237-240, Springer-Verlag, Heidelberg, Germany, 2007.
- [ID-ULA] Hinden, R., Huston, G., and T. Narten, "Centrally Assigned Unique Local IPv6 Unicast Addresses", Work in Progress, June 2007.
- [IEEE-EUI] IEEE, "Guidelines for 64-bit Global Identifier (EUI-64) Registration Authority", Piscataway, NJ, USA, March 1997, <<http://standards.ieee.org/regauth/oui/tutorials/EUI64.html>>.

- [IEN1] Bennett, C., Edge, S., and A. Hinchley, "Issues in the Interconnection of Datagram Networks", Internet Experiment Note (IEN) 1, INDRA Note 637, PSPWN 76, 29 July 1977, <<http://www.rfc-editor.org/ien/ien1.pdf>>.
- [IEN19] Shoch, J., "Inter-Network Naming, Addressing, and Routing", IEN 19, January 1978, <<http://www.rfc-editor.org/ien/ien19.txt>>.
- [IEN23] Cohen, D., "On Names, Addresses, and Routings", IEN 23, January 1978, <<http://www.rfc-editor.org/ien/ien23.pdf>>.
- [IEN31] Cohen, D., "On Names, Addresses, and Routings (II)", IEN 31, April 1978, <<http://www.rfc-editor.org/ien/ien31.pdf>>.
- [IEN135] Sunshine, C. and J. Postel, "Addressing Mobile Hosts in the ARPA Internet Environment", IEN 135, March 1980, <<http://www.rfc-editor.org/ien/ien135.pdf>>.
- [IPng95] Clark, D., "A thought on addressing", electronic mail message to IETF IPng WG, Message-ID: 9501111901.AA28426@caraway.lcs.mit.edu, Laboratory for Computer Science, MIT, Cambridge, MA, USA, 11 January 1995.
- [LA2006] Liu, C. and P. Albitz, "DNS & Bind", 5th Edition, O'Reilly & Associates, Sebastopol, CA, USA, May 2006, ISBN 0-596-10057-4.
- [LABH06] Lad, M., Atkinson, R., Bhatti, S., and S. Hailes, "A Proposal for Coalition Networking in Dynamic Operational Environments", Proceedings of IEEE Military Communications Conference, Washington, DC, USA, Nov. 2006.
- [PHG02] Pappas, A., Hailes, S., and R. Giaffreda, "Mobile Host Location Tracking through DNS", Proceedings of IEEE London Communications Symposium, IEEE, London, England, UK, September 2002.
- [RAB09] Rehunathan, D., Atkinson, R., and S. Bhatti, "Enabling Mobile Networks Through Secure Naming", Proceedings of IEEE Military Communications Conference (MILCOM), Boston, MA, USA, October 2009.

- [RB10] Rehunathan, D. and S. Bhatti, "A Comparative Assessment of Routing for Mobile Networks", Proceedings of IEEE International Conference on Wireless and Mobile Computing Networking and Communications (WiMob), IEEE, Niagara Falls, ON, Canada, Oct. 2010.
- [SBK01] Snoeren, A., Balakrishnan, H., and M. Frans Kaashoek, "Reconsidering Internet Mobility", Proceedings of 8th Workshop on Hot Topics in Operating Systems, IEEE, Elmau, Germany, May 2001.
- [SIPP94] Smart, B., "Re: IPng Directorate meeting in Chicago; possible SIPP changes", electronic mail to the IETF SIPP WG mailing list, Message-ID: 199406020647.AA09887@shark.mel.dit.csiro.au, Commonwealth Scientific & Industrial Research Organisation (CSIRO), Melbourne, VIC, 3001, Australia, 2 June 1994.
- [SRC84] Saltzer, J., Reed, D., and D. Clark, "End to End Arguments in System Design", ACM Transactions on Computer Systems, Volume 2, Number 4, ACM, New York, NY, USA, November 1984.
- [RFC814] Clark, D., "Name, addresses, ports, and routes", RFC 814, July 1982.
- [RFC1112] Deering, S., "Host extensions for IP multicasting", STD 5, RFC 1112, August 1989.
- [RFC1122] Braden, R., Ed., "Requirements for Internet Hosts - Communication Layers", STD 3, RFC 1122, October 1989.
- [RFC1498] Saltzer, J., "On the Naming and Binding of Network Destinations", RFC 1498, August 1993.
- [RFC1631] Egevang, K. and P. Francis, "The IP Network Address Translator (NAT)", RFC 1631, May 1994.
- [RFC1825] Atkinson, R., "Security Architecture for the Internet Protocol", RFC 1825, August 1995.
- [RFC1826] Atkinson, R., "IP Authentication Header", RFC 1826, August 1995.
- [RFC1827] Atkinson, R., "IP Encapsulating Security Payload (ESP)", RFC 1827, August 1995.

- [RFC1958] Carpenter, B., Ed., "Architectural Principles of the Internet", RFC 1958, June 1996.
- [RFC1992] Castineyra, I., Chiappa, N., and M. Steenstrup, "The Nimrod Routing Architecture", RFC 1992, August 1996.
- [RFC2002] Perkins, C., Ed., "IP Mobility Support", RFC 2002, October 1996.
- [RFC2101] Carpenter, B., Crowcroft, J., and Y. Rekhter, "IPv4 Address Behaviour Today", RFC 2101, February 1997.
- [RFC2136] Vixie, P., Ed., Thomson, S., Rekhter, Y., and J. Bound, "Dynamic Updates in the Domain Name System (DNS UPDATE)", RFC 2136, April 1997.
- [RFC2710] Deering, S., Fenner, W., and B. Haberman, "Multicast Listener Discovery (MLD) for IPv6", RFC 2710, October 1999.
- [RFC2827] Ferguson, P. and D. Senie, "Network Ingress Filtering: Defeating Denial of Service Attacks which employ IP Source Address Spoofing", BCP 38, RFC 2827, May 2000.
- [RFC2956] Kaat, M., "Overview of 1999 IAB Network Layer Workshop", RFC 2956, October 2000.
- [RFC3022] Srisuresh, P. and K. Egevang, "Traditional IP Network Address Translator (Traditional NAT)", RFC 3022, January 2001.
- [RFC3027] Holdrege, M. and P. Srisuresh, "Protocol Complications with the IP Network Address Translator", RFC 3027, January 2001.
- [RFC3177] IAB and IESG, "IAB/IESG Recommendations on IPv6 Address Allocations to Sites", RFC 3177, September 2001.
- [RFC3376] Cain, B., Deering, S., Kouvelas, I., Fenner, B., and A. Thyagarajan, "Internet Group Management Protocol, Version 3", RFC 3376, October 2002.
- [RFC3704] Baker, F. and P. Savola, "Ingress Filtering for Multihomed Networks", BCP 84, RFC 3704, March 2004.
- [RFC3715] Aboba, B. and W. Dixon, "IPsec-Network Address Translation (NAT) Compatibility Requirements", RFC 3715, March 2004.

- [RFC3810] Vida, R., Ed., and L. Costa, Ed., "Multicast Listener Discovery Version 2 (MLDv2) for IPv6", RFC 3810, June 2004.
- [RFC3948] Huttunen, A., Swander, B., Volpe, V., DiBurro, L., and M. Stenberg, "UDP Encapsulation of IPsec ESP Packets", RFC 3948, January 2005.
- [RFC3971] Arkko, J., Ed., Kempf, J., Zill, B., and P. Nikander, "SEcure Neighbor Discovery (SEND)", RFC 3971, March 2005.
- [RFC3972] Aura, T., "Cryptographically Generated Addresses (CGA)", RFC 3972, March 2005.
- [RFC4193] Hinden, R. and B. Haberman, "Unique Local IPv6 Unicast Addresses", RFC 4193, October 2005.
- [RFC4291] Hinden, R. and S. Deering, "IP Version 6 Addressing Architecture", RFC 4291, February 2006.
- [RFC4581] Bagnulo, M. and J. Arkko, "Cryptographically Generated Addresses (CGA) Extension Field Format", RFC 4581, October 2006.
- [RFC4941] Narten, T., Draves, R., and S. Krishnan, "Privacy Extensions for Stateless Address Autoconfiguration in IPv6", RFC 4941, September 2007.
- [RFC4982] Bagnulo, M. and J. Arkko, "Support for Multiple Hash Algorithms in Cryptographically Generated Addresses (CGAs)", RFC 4982, July 2007.
- [RFC4984] Meyer, D., Ed., Zhang, L., Ed., and K. Fall, Ed., "Report from the IAB Workshop on Routing and Addressing", RFC 4984, September 2007.
- [RFC5061] Stewart, R., Xie, Q., Tuexen, M., Maruyama, S., and M. Kozuka, "Stream Control Transmission Protocol (SCTP) Dynamic Address Reconfiguration", RFC 5061, September 2007.
- [RFC5570] StJohns, M., Atkinson, R., and G. Thomas, "Common Architecture Label IPv6 Security Option (CALIPSO)", RFC 5570, July 2009.
- [RFC6177] Narten, T., Huston, G., and L. Roberts, "IPv6 Address Assignment to End Sites", BCP 157, RFC 6177, March 2011.

- [RFC6250] Thaler, D., "Evolution of the IP Model", RFC 6250, May 2011.
- [RFC6275] Perkins, C., Ed., Johnson, D., and J. Arkko, "Mobility Support in IPv6", RFC 6275, July 2011.
- [RFC6748] Atkinson, R. and S. Bhatti, "Optional Advanced Deployment Scenarios for the Identifier-Locator Network Protocol (ILNP)", RFC 6748, November 2012.

12. Acknowledgements

Steve Blake, Stephane Bortzmeyer, Mohamed Boucadair, Noel Chiappa, Wes George, Steve Hailes, Joel Halpern, Mark Handley, Volker Hilt, Paul Jakma, Dae-Young Kim, Tony Li, Yakov Rehkter, Bruce Simpson, Robin Whittle, and John Wroclawski (in alphabetical order) provided review and feedback on earlier versions of this document. Steve Blake provided an especially thorough review of an early version of the entire ILNP document set, which was extremely helpful. We also wish to thank the anonymous reviewers of the various ILNP papers for their feedback.

Roy Arends provided expert guidance on technical and procedural aspects of DNS issues.

Noel Chiappa graciously provided the authors with copies of the original email messages cited here as [SIPP94] and [IPng95], which enabled the precise citation of those messages herein.

Authors' Addresses

RJ Atkinson
Consultant
San Jose, CA 95125
USA

EMail: rja.lists@gmail.com

SN Bhatti
School of Computer Science
University of St Andrews
North Haugh, St Andrews
Fife KY16 9SX
Scotland, UK

EMail: saleem@cs.st-andrews.ac.uk

